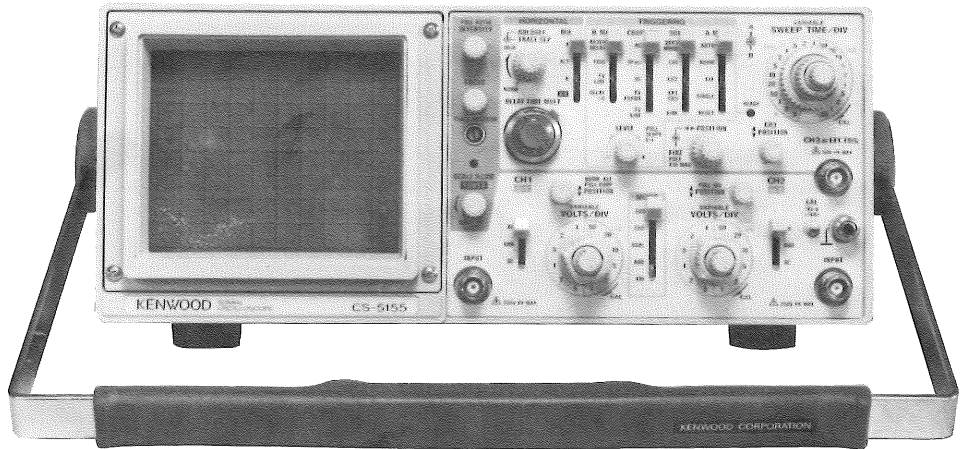


50MHz OSCILLOSCOPE

# CS-5155

## SERVICE MANUAL

KENWOOD CORPORATION



KENWOOD

## WARNING

1. The following instructions are for use by qualified personnel only. To avoid electric shock, do not perform any servicing other than contained in the operating instructions unless you are qualified to do so.
  
2. High voltage up to 12000 volts DC is present when the oscilloscope is operating. Line voltage (100 to 240 VAC) is present on the power transformer, on-off switch, fuse holder, and line voltage selector, any time the oscilloscope is connected to an AC power source, even if turned off. Always observe caution whether the AC plug is removed from the AC power source. Contacting exposed high voltage could result in fatal electric shock.

## CONTENTS

SPECIFICATIONS .....	3
SAFETY .....	6
BLOCK DIAGRAM .....	7
CIRCUIT DESCRIPTION .....	8
ADJUSTMENT .....	10
TROUBLESHOOTING .....	17
PARTS LIST .....	21
P.C. BOARD .....	33
SCHEMATIC DIAGRAM.....	35
DISASSEMBLY .....	38
SEMICONDUCTORS .....	39

# SPECIFICATIONS

<b>CRT</b>	
	Rectangular, with internal graticule
Acceleration Voltage	12 kV
Display Area	8 × 10 div (1 div = 10 mm)
<b>VERTICAL AXIS</b>	<b>CH1 and CH2</b>
Sensitivity	1 mV/div to 5 V/div, ± 3%
Attenuator	12 steps, 1 mV/div to 5 V/div in 1-2-5 sequence. Vernier control for fully adjustable sensitivity between steps.
Input Impedance	1 MΩ ± 2%, approx 20 pF
Frequency Response	
5 mV/div to 5V/div	DC; DC to 50 MHz, - 3 dB AC; 5 Hz to 50 MHz, - 3 dB
1 mV/div, 2 mV/div	DC; DC to 20 MHz, - 3 dB AC; 5 Hz to 20 MHz, - 3 dB
Rise Time	5 mV/div to 5 V/div 1 mV/div, 2 mV/div
	5.8 ns or less 17.5 ns or less
Signal Delay Time	Approx. 20 ns on the CRT screen
Crosstalk	- 40 dB minimum
Operating Modes	CH1; single trace CH2; single trace DUAL; CH1 and CH2, dual trace ADD; CH1 + CH2 added as a single trace TRIPLE; CH1, CH2 and CH3 triple trace
Chop Frequency	Approx. 250 kHz
Channel Polarity	Normal or inverted, channel 2 only inverted
△ Maximum Input voltage	500 Vp-p or 250 V (DC + AC peak)
Non-Distorted Maximum Amplitude	More than 8 div (DC to 50 MHz)
<b>VERTICAL AXIS</b>	<b>CH3</b>
Sensitivity	0.5 V/div ± 3%
Input Resistance	1 MΩ ± 2%
Input Capacitance	Approx. 20pF
Frequency Response	DC: DC to 50 MHz, - 3 dB
Rise Time	5.8 ns or less
Signal Delay Time	Same as CH1 and CH2
△ Maximum Input Voltage	50 V (DC + AC peak)
<b>HORIZONTAL AXIS</b>	<b>Input thru CH2, × 10 MAG not included</b>
Operating Modes	With HORIZ MODE switch, X-Y operation is selectable CH1; Y axis CH2; X axis
Sensitivity	Same as vertical axis (CH2)

# SPECIFICATIONS

HORIZONTAL AXIS (cont)				
Input Impedance		Same as vertical axis (CH2)		
Frequency Response		DC; DC to 1 MHz, - 3 dB AC; 5 Hz to 1 MHz, - 3 dB		
X-Y Phase Difference		3° or less at 100 kHz		
⚠ Maximum Input Voltage		Same as vertical axis (CH2)		
<b>SWEEP</b>				
Type		A; A sweep ALT; A sweep (intensified for duration of B sweep) and B sweep (delayed sweep) alternating B; Delayed sweep X-Y; X-Y oscilloscope		
Sweep Time	A	0.05 $\mu$ s/div to 0.5 s/div, $\pm$ 3% in 22 ranges, in 1-2-5 sequence. Vernier control provides fully adjustable sweep time between steps.		
	B	0.05 $\mu$ s/div to 50 ms/div in 19 ranges, in 1-2-5 sequence.		
Sweep Magnification		$\times$ 10 (ten times) $\pm$ 5% (0.05 $\mu$ s ~ 0.2 $\mu$ s; $\pm$ 8%)		
Linearity		$\pm$ 3% all ranges, $\pm$ 5% on 0.05 $\mu$ s/div to 0.2 $\mu$ s/div range at $\times$ 10 MAG.		
Holdoff		Continuously variable from NORM to more than ten times (MAX)		
Trace Separation		B sweep can be separated from A sweep up to 4 divisions, continuously adjustable.		
Delay Method		Continuous delay (AFTER DELAY), Trigger delay (TRIG, TV LINE), Zero delay (DELAY = 0)		
Delay Time		From 500 ns to 0.5s. Available delay time is 0.2 to 10 times the A sweep time setting, continuously adjustable.		
Delay accuracy		$\pm$ (1% of set value + 3% of full scale) - 0 to - 100 ns		
Delay Jitter		1/20000 of ten times of A sweep time setting		
<b>TRIGGERING</b>				
Trigger mode		AUTO, NORM, FIX, SINGLE-RESET		
Trigger source		V.MODE; Trigger selected by vertical MODE switch. CH1; Triggered by CH1 signal CH2; Triggered by CH2 signal CH3/EXT; Triggered by CH3 signal LINE; Triggered by line voltage		
Coupling		AC, HF <sub>REJ</sub> , DC, TV FRAME, TV LINE		
Trigger sensitivity		FREQ.RANGE	INT	EXT
	DC	DC to 50 MHz	1 div	0.5 Vp-p
	AC	Same as for DC but increased minimum level below 10 Hz		
	AC, HF <sub>REJ</sub>	Increased minimum level below 10 Hz and above 20 kHz		
	TV	FRAME, LINE	1 div	0.5 Vp-p
		AUTO: Same as above specifications for above 50 Hz. FIX: Same as above specifications for above 50 Hz.		



# SPECIFICATIONS

<b>CAL</b>	1 V, $\pm 3\%$ , square wave, positive polarity, approx 1 kHz
<b>INTENSITY MODULATION</b>	
Sensitivity	+ 5 V (positive voltage decreases brightness)
Input Impedance	Approx. 10 k $\Omega$
Usable Frequency Range	DC to 5 MHz
$\Delta$ Maximum Input Voltage	50 V (DC + AC peak)
<b>VERTICAL AXIS SIGNAL OUTPUT</b>	CH1 OUTPUT
Output Voltage	Approx. 50 mV/div into 50 $\Omega$
Output Impedance	Approx. 50 $\Omega$
Frequency Response	
5 mV/div to 5 V/div	100 Hz to 50 MHz, - 3 dB into 50 $\Omega$
1 mV/div, 2 mV/div	100 Hz to 20 MHz, - 3 dB into 50 $\Omega$
<b>POWER REQUIREMENT</b>	
Power Supply	100 V/120 V/220 V/240 V $\pm 10\%$
Line Frequency	50/60 Hz
Power Consumption	Approx. 61 W
<b>DIMENSIONS (W <math>\times</math> H <math>\times</math> D)</b>	319(359) $\times$ 132(145) $\times$ 380(454) mm ( ) dimensions include protrusion from basic outline dimensions
<b>WEIGHT</b>	Approx. 9.2 kg
<b>ENVIRONMENTAL</b>	
Within Specifications	10°C to 35°C, 85% max. relative humidity
Full Operation	0°C to 40°C, 85% max. relative humidity
<b>ACCESSORIES SUPPLIED</b>	
Probe	PC-39.....2
Spare Fuse	1 A.....2 0.7 A.....2
Instruction Manual	1

\* Circuit and rating are subject to change without notice due to developments in technology.

# SAFETY

## SAFETY

Before connecting the instrument to a power source, carefully read the following information, then verify that the proper power cord is used and the proper line fuse is installed for power source. The specified voltage is shown at the fuse holder of the AC inlet. If the power cord is not applied for specified voltage, there is always a certain amount of danger from electric shock.

### Line voltage

This instrument operates using ac-power input voltages that 100/120/220/240 V at frequencies from 50 Hz to 60 Hz.

### Power cord

The ground wire of the 3-wire ac power plug places the chassis and housing of the oscilloscope at earth ground. Do not attempt to defeat the ground wire connection or float the oscilloscope; to do so may pose a great safety hazard. The appropriate power cord is supplied by an option that is specified when the instrument is ordered.

The optional power cords are shown as follows in Fig. 1.

### Line fuse

The fuse holder is located on the rear panel and contains the line fuse. Verify that the proper fuse is installed by replacing the line fuse.

### Voltage conversion

This oscilloscope may be operated from either a 100 V to 240 V, 50/60 Hz power source. Use the following procedure to change from 100 to 240 volt operation or vice versa.

1. Remove the fuse holder.
2. Replace fuse F 1 with a fuse of appropriate value, 1 amp for 100 VAC to 120 VAC operation, 0.7 amp for 220 VAC to 240 VAC operation.
3. Reinsert it for appropriate voltage range.
4. When performing the reinsertion of fuse holder for the voltage conversion the appropriate power cord should be used. (See Fig. 1.)

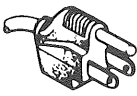
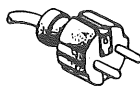


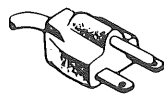
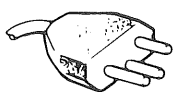
Plug configuration	Power cord and plug type	Factory installed instrument fuse	Line cord plug fuse	Parts No. for power cord and plate
	North American 120 volt/60 Hz Rated 15 amp (12 amp max; NEC)	1 A, 250 V Fast blow AGC/3AG	None	Cord: E30-1820-05
	Universal Europe 220 volt/50 Hz Rated 16 amp	North Europe 630 mA, 250 V Slow blow 5 × 20 mm  Other Europe 0.7 A, 250 V Fast blow 6 × 30 mm	None	Cord: E30-1819-05
	U.K. 240 volt/50 Hz Rated 13 amp	0.7 A, 250 V Fast blow 5 × 20 mm	0.7 A Type C	—
	Australian 240 volt/50 Hz Rated 10 amp	0.7 A, 250 V Fast blow 5 × 20 mm	None	Cord: E30-1821-05
	North American 240 volt/60 Hz Rated 15 amp (12 amp max; NEC)	0.7 A, 250 V Fast blow AGC/3AG	None	—
	Switzerland 240 volt/50 Hz Rated 10 amp	0.7 A, 250 V Fast blow AGC/3AG 5 × 20 mm	None	—

Fig. 1 Power Input Voltage Configuration

# BLOCK DIAGRAM

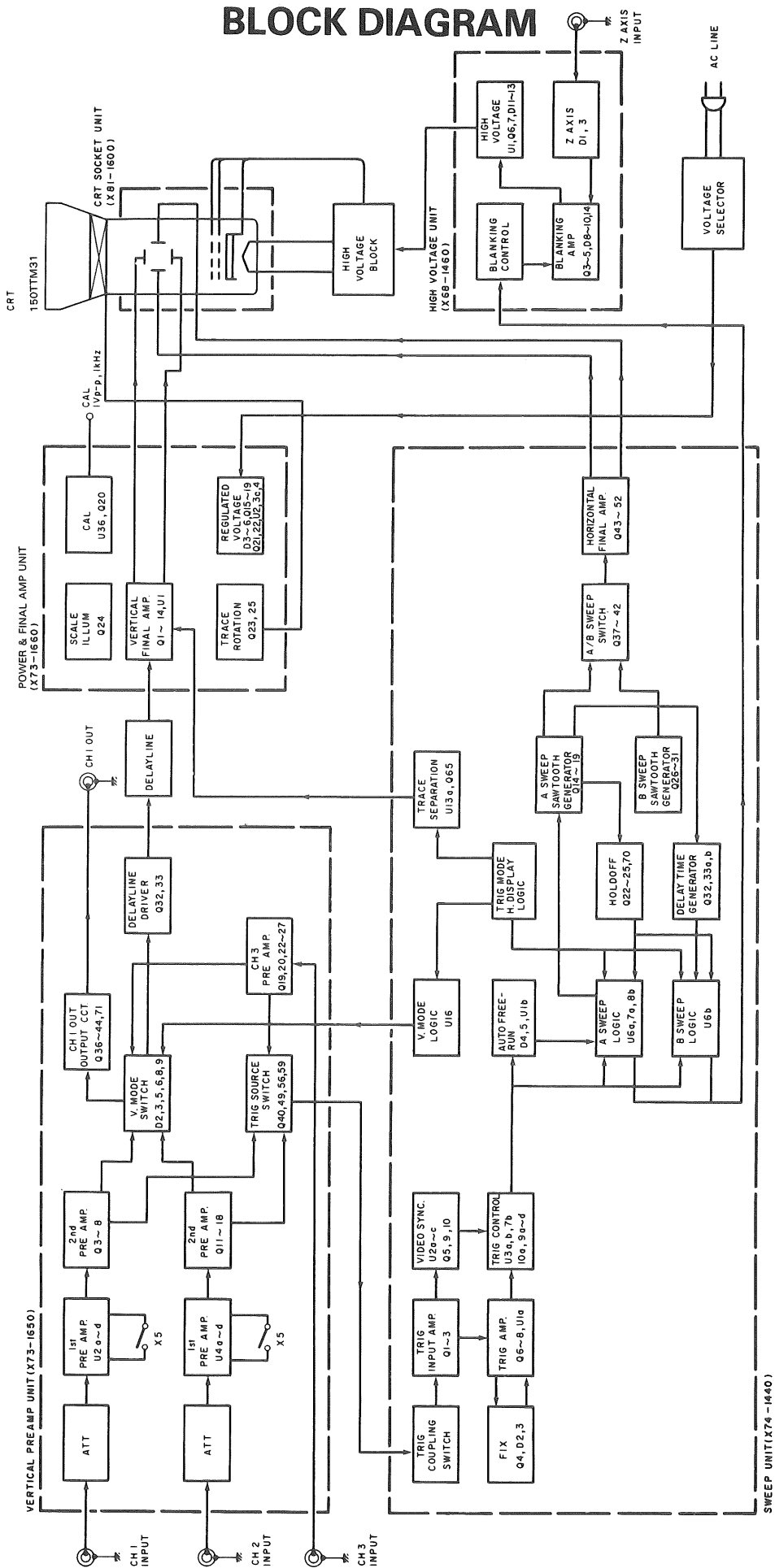


Fig. 2  
Block diagram

# CIRCUIT DESCRIPTION

## 1. VERTICAL PREAMPLIFIER CIRCUIT (X73-1650)

The signals from the input BNC of channel 1 and channel 2 are attenuated to a suitable value by 1st ATT, Q1, Q2, and Q69 of the head amplifier (Q9, Q10, and Q70 for channel 2), and 2nd ATT, and are then sent to U2a-e, Q3 and Q4 of the 1st preamp. DC feedback is applied to the head amplifiers from the op amp in order to reduce DC balance drift. The 1st preamp is a selectable gain type amplifier. When the range is set to 1 mV/div or 2 mV/div, the gain of the 1st preamp becomes 5 times the normal gain. Also, an adequate CMRR is obtained.

The signals from the 1st preamp pass through the emitter follower consisting of Q65 and Q66, then enter the 2nd preamplifier-cum-vertical mode switch consisting of Q5-Q8. Here, the CH1 ~ CH3 signals are switched by the V-MODE switch, and then sent to the delay line driver. Like the CH1 signals, the CH2 signals pass through the head amplifier, U4a-e, and Q11-Q14 of the 1st preamplifier, Q67 and Q68 of the emitter follower, and Q15-Q18 of the 2nd preamplifier. Q11 and Q14 are for CH2 INV, and are not provided in channel 1.

The input sensitivity of channel 3 is 0.5 V/div which is low compared with that of the other channels, hence 1/10 ATT is provided at the input. The signals which are attenuated by ATT pass through Q19, Q20, Q22, and Q23 of the head amplifier, then enter Q24-Q27 of the mode selector which is equivalent to the 2nd preamplifier of channel 1 and channel 2.

The delay line driver consists of Q30-Q33. Of these, Q32 and Q33 are connected in cascode with the based-grounded transistors Q1 and Q2 in the first stage of the vertical final amplifier. The delay line is inserted between the collector and emitter of this cascode amplifier.

## 2. TRIGGER SIGNAL SWITCHING CIRCUIT (X73-1650)

The trigger signals which are output differentially from each channel enter Q36-Q40, Q45-Q49, and Q52-Q56 of the respective trigger switching circuits. The line trigger signals from the power supply circuit enter the trigger switching circuit consisting of Q57-Q59.

The four trigger signals (Channel 1 to Channel 3, and LINE) pass through Q57-Q60, and are selected in accordance with the switching signals from the horizontal sweep unit. They then pass through the trigger output amplifier consisting of Q60 and Q61, and are sent from P10 to the horizontal sweep unit.

The signals from CH1 OUT are branched from the trigger switching circuit of channel 1, then pass through Q42, Q43, Q71, and Q44 of the output circuit, and are output from P17.

## 3. VERTICAL FINAL AMPLIFIER (X73-1660)

The signals which pass through the delay line are terminated by Q1 and Q2, and then amplified by Q3-Q6 of the cascode amplifier in the next stage.

The signals which have been converted to low impedance by the emitter follower of Q7 and Q8 are amplified to the 2.3 V/div (one side) deflection sensitivity of the CRT by Q9-Q14 of the final stage amplifier.

U1 is a servo circuit which is designed to regulate the operating point of the final stage amplifier. By means of this circuit, the deflection plates are maintained at a constant average voltage.

## 4. POWER SUPPLY CIRCUIT (X73-1660)

The power supply provides five regulated voltages, two unregulated voltages, and also one scale illumination output. When the power switch is turned ON, first +10 V is provided by Q22 and U2a, and -10 V is provided by Q21 and U2b. The 5 V, 55 V, and 120 V outputs are regulated with reference to this -10 V.

Q26 and Q27 are ripple filters which are used for the unregulated +12 V and -12 V voltages.

The voltage for the scale illumination lamp is rectified by D6 and controlled by Q24.

## 5. TRACE ROTATION AND CAL CIRCUIT (X73-1660)

The trace rotation circuit is consisted of emitter follower of Q23 and Q25. It drives the rotator coil which is located on the cone of the CRT. The CAL circuit is an oscillator circuit consisting of the op amp U3b. It generates 1 kHz square wave which is switched by Q20 to become a 1 Vp-p CAL signal.

## 6. BLANKING CIRCUIT AND HIGH VOLTAGE CIRCUIT (X68-1460)

The unblanking signals from P11 are inverted and amplified by the blanking amplifier consisting of Q3-Q5, and are then superimposed on the cathode voltage by the DC recovery circuit consisting of D8-D10.

Q1 and Q2 constitutes an inverted amplifier for auto-focusing. It creates the focusing voltage from the blanking signals. The focusing voltage is superimposed on the high voltage by the DC recovery circuit consisting of D4-D6, and then used to drive the focusing electrode. The -1.5 kV high voltage for the cathode is generated by the converter oscillation circuit consisting of U1, Q6 and Q7, and also the high voltage converter block (W02-0423-05). Negative feedback is applied to the converter oscillation circuit from the cathode in order to obtain a regulated high voltage.

# CIRCUIT DESCRIPTION

## 7. TRIGGER CIRCUIT (X74-1440)

The trigger signals sent from the vertical system pass through P10 then enter the trigger amplifier consisting of Q1-Q3, Q6, and Q7, where they are amplified to operate the ECL logic. Q4, Q8, and U1a constitute the trigger level setting circuit which is used for FIX synchronization. This circuit detects the peak-to-peak value of the signal, and takes it off as a center point voltage.

Q9 is a sync separator circuit which is used for TV synchronization. It clamps the sync tip and extracts the sync pulses. These pulses are then passed through an integrating circuit consisting of R39 and C19 in order to obtain the vertical sync pulses.

The signals which leave the trigger amplifier are wave-shaped by the Schmitt trigger circuit consisting of U4a and b, and the trigger slope is selected by U4c. These signals and the previously mentioned TV sync pulses drive the subsequent horizontal sweep circuit.

## 8. HORIZONTAL SWEEP CIRCUIT (X74-1440)

When the trigger pulses trigger flip-flop U6, the output will be inverted, and the Miller integrater circuit, which consists of Q16, Q17 and a group of RC circuits that can be selected by a rotary switch, starts the sweep. The sweep signal is output for an interval (sweep length) determined by the comparator consisting of Q20 and Q21, and the RS flip-flop consisting of U5a and U10b, then after a rest period determined by the hold-off circuit consisting of Q22, the flip-flop waits for the next trigger signal.

The B sweep takes place when flip-flop U6 is switched after a delay which is determined by the comparator consisting of Q32-Q34 and the voltage from the potentiometer. The sweep signal is generated by the Miller integrating circuit for B sweep consisting of Q28 and Q29.

The A sweep and B sweep signals are switched by Q67, Q37, Q40, and Q41 of the sweep switching circuit, and are sent to the horizontal final amplifier consisting of Q43-Q52.

## 9. CHANNEL SWITCHING SIGNAL GENERATOR CIRCUIT (X14-1440)

This is a timing generator circuit which is designed to turn each channel ON-OFF for DUAL and TRIPLE operation. U13c and d are CHOP generators for CHOP operation, and U11a and b are frequency divider circuits for DUAL or TRIPLE operation. The clock used for the frequency divider circuits for ALT operation is A blanking, and that used for CHOP operation is the AND signal resulting from A blanking and the output of the CHOP generator.

During V-MODE operation, the channel switching signal becomes the trigger selector signal. In all other cases, only the necessary trigger signal can be selected.

## 10. UNBLANKING SIGNAL GENERATOR CIRCUIT (X74-1440)

The unblanking signal is formed by the switching of A blanking and B blanking in each sweep mode. It is output from the emitter of Q68 superimposed on the intensity voltage.

# ADJUSTMENT

To obtain the best performance, periodically calibrate the unit. Sometimes, only one mode need be calibrated, while at other times, all modes should be calibrated. When one mode is calibrated, it must be noted that the other modes may be affected. When calibrating all modes, perform the calibration in the specified sequence.

The following calibration required an accurate measuring instrument and an insulated adjusting flat blade screwdriver. If they are not available, contact your dealer. For optimum adjustment, turn the power on and warm up the scope sufficiently (more than 30 minutes) before starting.

Before calibrating the scope, check the power supply voltage.

## TEST EQUIPMENT REQUIRED

The following instrument or their equivalent should be used for making adjustment.

Test Equipment	Model	Minimum Specification
Digital Multi-Meter	DL-706 (KENWOOD)	Impedance: More than 10 M $\Omega$ , Measuring range: 0.01 V to 199 V
Sine-Wave Generator	651 B (YHP)	Frequency: 10 Hz to 10 MHz, constant voltage over tuning range
Sine-Wave Generator	SG-503 (Tektronix)	Frequency: 50 kHz to 100 MHz, Output impedance: 50 $\Omega$ , constant voltage over tuning range.
Square-Wave Generator	PG-506 (Tektronix)	Output signal: 1 kHz, Amplitude: 10 mVp-p to 10 Vp-p, Accuracy: within $\pm 1\%$ , Rise time: 35ns or less 100 kHz, Rise time: 1 ns or less
Q Meter	4343B (YHP)	—
Color Pattern Generator	CG-911A (KENWOOD)	—
Oscilloscope	CS-2100A (KENWOOD)	Sensitivity: more than 5 mV Frequency response: More than 100 MHz
Time-Marker Generator	TG-501 (Tektronix)	Time mark: 0.5 s to 0.1 $\mu$ s repetitive waveform
High-Voltage Probe	—	Input Impedance: 1000 M $\Omega$
Termination	—	Impedance: 50 $\Omega$ Accuracy: within 3%
Termination	—	3 watts type impedance: 50 $\Omega$
Attenuator	—	-20 dB attenuation (50 $\Omega$ )

Table 1

## PREPARATION FOR ADJUSTMENT

### Control Setting

The control setting listed below must be used for each adjustment procedure.

Exceptions to these settings will be noted as they occur. After completing a adjustment, return the controls to the following settings.

NAME OF KNOBS	POSITION
INTENSITY	3 o'clock
FOCUS, ASTIG	Optimum position
CH1, CH2 $\updownarrow$ POSITION	Mechanical center
$\blacktriangleleft \blacktriangleright$ POSITION/PULL $\times 10$ MAG VARIABLE, A VARIABLE (VOLTS/DIV, SWEEP TIME/DIV)	Mechanical center, push CAL
AC-GND-DC (CH1 and CH2)	DC (GND at no signal)
Vertical MODE	CH1
CH2 POLARITY	NORM
COUPLING	AC
SOURCE	V.MODE
TRIG. LEVEL	Mechanical center, push
TRIG. MODE	AUTO
VOLTS/DIV (CH1 and CH2)	10 mV/DIV
A, B SWEEP TIME/DIV	1 ms/DIV
HOLD OFF	Fully CCW, NORM, Push
B MODE	DELAY TIME ZERO
HORIZ MODE	A
DELAY TIME MULT	Optimum position

Table 2

# ADJUSTMENT

## POWER AND CRT ADJUSTMENT

### Reference voltage (– 10 V) adjustment

1. Connect a dc voltmeter to measure the voltage at P9 (Pin no.3) (X73-1660) with respect to the chassis.
2. Adjust VR1 for  $-10\text{ V} \pm 0.1\text{ V}$  reading on the meter.

### Reference voltage check

1. Connect a dc voltage to measure the voltage at P9 (X73-1660) as shown in table 1.

Pin no.	5	4	2	1
Voltage	$120\text{V} \pm 6\text{V}$	$60\text{V} \pm 3\text{V}$	$10\text{V} \pm 0.5\text{V}$	$5\text{V} \pm 0.25\text{V}$

Table 3

2. Connect a dc voltmeter to measure the voltage at P1 (X81-1600) using a high voltage probe and check the voltage for  $-1.5\text{ kV} \pm 0.07\text{ kV}$  reading on the meter.

### ASTIG and FOCUS adjustment

1. Select the HORIZ DISPLAY switch to X-Y position and both channel 1 and channel 2 AC-GND-DC switches to GND positions.
2. Pull the PULL ASTIG control and adjust the FOCUS control for the sharpest, roundest spot when centering the ASTIG and FOCUS controls.

### INTENSITY adjustment

1. Select the HORIZ DISPLAY switch to X-Y position and both channel 1 and channel 2 AC-GND-DC switches to GND positions.
2. Adjust VR1 (X68-1460) so that the trace disappears when the INTENSITY control setting is reduced to 10:00 position.
3. Clockwise rotation should increase brightness of the trace and counterclockwise rotation should decrease brightness of the trace. Fully counterclockwise should disappear the spot.

### TRACE ROTATION adjustment

1. Set the channel 1 AC-GND-DC switch to GND position.
2. Set the scope controls to display a horizontal trace with no input signal (triggering MODE switch in AUTO position).
3. Use the channel 1 position control as required to position the trace along a horizontal line of the graticule scale.
4. Adjust TRACE ROTATION control so trace is parallel with the reference line on the graticule scale.

## VERTICAL AXIS ADJUSTMENT

### Channel 1 and channel 2 dc balance adjustment

1. Set the scope controls for a single horizontal trace on channel 1 with the channel 1 AC-GND-DC switch set to GND position.
2. Rotate the channel 1 VOLTS/DIV switch through the 5 mV, 10 mV, 20 mV and 50 mV positions while observing the trace.
3. If the trace moves vertically, adjust VR1 (X73-1650) (CH2; VR10) for minimum or zero vertical movement when performing step 2.
4. Rotate the channel 1 VOLTS/DIV switch through 1 mV, and 2 mV positions while observing the trace.
5. If the trace moves vertically, adjust VR4 (X73-1650) (CH2: VR13) for minimum or zero vertical movement when performing step 4.
6. Rotate the channel 1 VARIABLE control from maximum clockwise to maximum counterclockwise, while observing the trace.
7. If the trace moves vertically, adjust VR3 (X73-1650) (CH2:VR12) for minimum or zero vertical movement when performing step 6.
8. Repeat the entire procedure for channel 2.

### Channel 2 invert position adjustment

1. Select CH2 mode and set the channel 2 position control to its mechanical center.
2. Pull the channel 2 position control and adjust VR16 (X73-1650) to center the trace vertically.
3. Repeat step 1 and 2 if necessary so trace does not shift when channel 2 position control is alternately pulled and pushed.

### Channel 1 Position adjustment

1. Select CH1 mode and set the channel 1 position control to its mechanical center.
2. Adjust VR7 (X73-1650) to center the trace vertically.

### Channel 2 Position adjustment

1. Select CH2 mode and set the channel 2 position control to its mechanical center.
2. Adjust VR17 (X73-1650) to center the trace vertically.

### Channel 3 Position adjustment

1. Select the vertical MODE switch to TRI and set triggering SOURCE switch to CH3 position.
2. Adjust VR19 (X73-1650) to center the trace vertically.

### Add position adjustment

1. Set the channel 1 and channel 2 position controls to their mechanical center and AC-GND-DC switches to GND positions and select the vertical MODE switch to ADD position.
2. Adjust VR26 (X73-1650) to center the trace vertically.

# ADJUSTMENT

## 100 Hz square wave compensation

1. Using a square wave generator, apply a 100 Hz square wave signal to oscilloscope input to display a waveform of 6 divisions vertical amplitude.
2. Adjust VR2 (X73-1650) for the best flat-top waveform.
3. Repeat the entire procedure for channel 2.

## Channel 1 gain adjustment

1. Apply a 50 mV peak to peak, 1 kHz square wave signal to channel 1 input and set the vertical MODE switch to CH1 position.  
Set the scope controls to display a square wave on the CRT screen.
2. Adjust VR8 (X73-1650) for exactly 5 divisions vertical amplitude.
3. Apply a 5 mV peak to peak, 1 kHz square wave signal to channel 1 input and set the vertical MODE switch to CH 1 position.  
Set the scope controls to display a square wave on the CRT screen.
4. Adjust VR30 (X73-1650) for exactly 5 divisions vertical amplitude.

## Channel 2 gain and X gain adjustment

1. Apply a 50 mV peak to peak, 1 kHz square wave signal to channel 2 input and set the vertical MODE switch to CH2, set the scope controls to display a square wave on the CRT screen.
2. Adjust VR18 (X73-1650) for exactly 5 divisions vertical amplitude.
3. Select the HORIZ MODE switch to X-Y position.
4. Adjust VR21 (X73-1650) for exactly 5 divisions horizontal deflection on the CRT screen.
5. Apply a 5 mV peak to peak, 1 kHz square wave signal to channel 2 input and set the vertical MODE switch to CH2, set the scope controls to display a square wave on the CRT screen.
6. Adjust VR31 (X73-1650) for exactly 5 divisions vertical amplitude.

## Channel 3 gain adjustment

1. Select the vertical MODE switch to TRI and set triggering SOURCE switch to CH3 position.
2. Apply a 2 V peak to peak, 1 kHz square wave signal to channel 3 input.
3. Adjust VR20 (X73-1650) to display a waveform of 4 divisions vertical amplitude.

## TRIGGERING AND CH3 POSITION ADJUSTMENT

### Triggering level adjustment

1. Apply a 1 kHz sine wave signal to channel 1 input and set the scope controls to display a waveform of 8 divisions vertical amplitude.
2. Set the triggering MODE switch to FIX position.
3. Adjust VR1 (X74-1440) so the triggering is satisfactory when the amplitude is less than 1 division.

### Triggering level center adjustment

1. Apply a 1 kHz sine wave signal to channel 1 input and set the scope controls to display a waveform of 8 divisions vertical amplitude.
2. Set the channel 1 position control to its mechanical center.
3. Adjust VR13 (X74-1440) to start the trace from the center of the graticule scale when rotating the triggering LEVEL control to its mechanical center.

### Channel 1 and channel 2 offset adjustment

1. Set the triggering SOURCE switch to CH1 position.
2. Apply a 1 kHz sine wave signal to channel 1 input and set the scope controls to start a waveform of 6 divisions vertical amplitude from the center graticule scale.
3. Adjust VR22 (X73-1650), if necessary, so the start point of the trace does not shift when switched the COUPLING switch to alternately AC and DC positions.
4. Repeat the entire procedure for channel 2 and channel 3, adjusting VR23, VR24 (X73-1650), respectively.

## VERTICAL AXIS ADJUSTMENT

### Channel 1 and channel 2 waveshape compensation

1. Apply a 1 kHz square wave signal to channel 1 input and set the scope controls to display a waveform of 6 divisions vertical amplitude.
2. Adjust TC13 (X73-1650) for the best flat-top waveform when setting the channel 1 VOLTS/DIV control to 0.1 V position and TC14 (X73-1650) when channel 1 VOLTS/DIV control to 1 V position.
3. Repeat the entire procedure for channel 2 (X73-1650), adjusting TC14 (X73-1650).

### Channel 3 waveshape compensation

1. Select the vertical MODE switch to TRI position and triggering SOURCE switch to CH3 position.
2. Apply a 1 kHz square wave signal to channel 3 input to display a waveform of 6 divisions vertical amplitude.
3. Adjust TC5 (X73-1650) for the best flat-top waveform.



# ADJUSTMENT

## Channel 1 and channel 2 input capacity adjustment

1. Rotate the channel 1 VOLTS/DIV control to 10 mV position and connect a Q meter to channel 1 input to measure the input capacity for  $20\text{pF} \pm 3\text{pF}$ .

Adjustment control		VOLTS/DIV setting
CH1	CH2	
TC11 (X73-1650)	TC15 (X73-1650)	0.1 V/div
TC12 (X73-1650)	TC16 (X73-1650)	1 V/div

Table 4

2. Repeat the entire procedure for channel 1 VOLTS/DIV control to 0.1 V position and 1 V position.
3. Repeat the entire procedure for channel 2 input capacity adjustment.

## Channel 1 overshoot adjustment

1. Apply a 1 MHz square wave signal to channel 1 input and set the scope controls to display a waveform of 6 divisions vertical amplitude.
2. Preset the adjustment controls as follows;  
TC2 ~ TC9 ; mechanical center  
(X73-1650)
3. Adjust the following controls listed in table below.

Se-quence	Adj. control	Unit no.	Procedure
1	TC1	X73-1660	High frequency range compensation for peak-top waveform.
2	TC2	X73-1660	High frequency range compensation for the best flat-top waveform.
3	VR3	X73-1660	High frequency range compensation for the best flat-top waveform.
4	TC9	X73-1650	Mid frequency range compensation for the flat waveform.
5	TC7	X73-1650	Mid frequency range compensation for the best flat-top waveform.
6	TC2	X73-1650	Mid and high frequency ranges compensation for the best flat-top waveform.

Table 5

## Channel 2 overshoot adjustment

1. Select the vertical MODE switch to CH2 position.
2. Apply a 1 MHz square wave signal to channel 2 input and set the scope controls to display a waveform of 6 divisions vertical amplitude.
3. Adjust the following controls listed in table below;

Se-quence	Adj. control	Unit no.	Procedure
1	TC4	X73-1650	Mid frequency range compensation for the best flat-top waveform.
2	VR3	X73-1660	High frequency range compensation for the best flat-top waveform.

Table 6

## Channel 3 overshoot adjustment

1. Select the vertical MODE switch to ALT and TRI positions and triggering SOURCE switch to CH3 position and SWEEP TIME/DIV control to any position.
2. Apply a 1 MHz square wave signal to channel 3 input and set the scope controls to display a waveform of 6 divisions vertical amplitude.
3. Adjust TC8 (X73-1650) to the best flat-top waveform for high frequency range compensation.
4. Adjust TC6 (X73-1650) to compensate the overshoot for minimum.

## HORIZONTAL AXIS ADJUSTMENT

### 1 ms sweep time, A and B sweep start points and MAG gain adjustment

1. Set the A and B SWEEP TIME/DIV controls to both 1 ms positions, channel 1 VOLTS/DIV control to 1 V position, B MODE switch to DELAY TIME ZERO position and HORIZ MODE switch to ALT position.
2. Apply a 1 ms marker signal to channel 1 input.
3. Adjust VR7 (X74-1440) so the first and 11th time marks of A sweep coincide with graticule scale.
4. Adjust VR10 (X74-1440) so the first and 11th time marks of B sweep coincide with graticule scale.
5. Adjust VR11 (X74-1440) to coincide the start point of A sweep with that of B sweep.
6. PULL the FINE control.
7. Adjust VR8 (X74-1440) so the each time mark of A sweep coincides with graticule scale.

### Mag centering adjustment

1. Set the B MODE switch to DELAY TIME ZERO, HORIZ MODE switch to ALT, A and B SWEEP TIME/DIV controls to both 1 mV and channel 1 VOLTS/DIV to 1 V positions.

# ADJUSTMENT

2. Apply a 5 ms marker signal to channel 1 input and set the scope controls to center the center of the A and B time marks.
3. Adjust VR9 (X74-1440) to center the center of the A and B time marks when pulled out the FINE control.
4. Repeat step 2 and 3.
5. The center time mark should not shift when setting the  $\times 10$  MAG switch to on.

## 10 ms sweep time adjustment

1. Set the B MODE switch to DELAY TIME ZERO, HORIZ MODE switch to ALT, A and B SWEEP TIME/DIV controls to both 10 ms and channel 1 VOLTS/DIV control to 1 V positions.
2. Apply a 10 ms time marker signal to channel 1 input and set the scope controls to center the A and B time marks.
3. Adjust VR2 (X74-1440) to center the center of A time mark when again pushed in horizontal position control.
4. Adjust VR4 (X74-1440) to center the center of B time mark when pushed in horizontal position control.

## 10 $\mu$ s sweep time adjustment

1. Set the B MODE switch to DELAY TIME ZERO, HORIZ MODE switch to ALT, A and B SWEEP TIME/DIV controls to both 10  $\mu$ s and channel 1 VOLTS/DIV control to 1 V positions.
2. Apply a 10  $\mu$ s time marker signal to channel 1 input and set the scope controls to center the center of A and B time marks.
3. Adjust TC1 (X74-1440) to center the center of A time mark when pushed in horizontal position control.
4. Adjust TC4 (X74-1440) to center the center of B time mark when again pushed in horizontal position control.

## Sweep linearity adjustment

1. Set the B MODE switch to DELAY TIME ZERO, HORIZ MODE switch to ALT, A and B SWEEP TIME/DIV controls to both 0.05  $\mu$ s and channel 1 VOLTS/DIV control to 1 V positions.
2. Apply a 0.05  $\mu$ s time marker signal to channel 1 input and the scope controls to center the center of A and B time marks.
3. Adjust TC5 (X74-1440) to center the center of A and B time marks.

## Horizontal Position Adjustment

1. SWEEP TIME/DIV: 1 ms
2. Horizontal POSITION: Mechanical center
3. Adjust VR16 (X74-1440) so that the start point of the luminescent line matches the vertical scale line at the left and of the CRT.

## Delay time multiplier adjustment

1. Set the B MODE switch to STARTS AFTER DELAY, HORIZ MODE switch to ALT, channel 1 AC-GND-DC switch to GND, A SWEEP TIME/DIV control to 0.1 ms and B SWEEP TIME/DIV control to 1  $\mu$ s positions.
2. Rotate the DELAY TIME MULT control to 0.20 position and set the scope controls to coincide A trace with the left end of the graticule scale, using the horizontal position control.
3. Adjust VR5 (X74-1440) to position B trace (intensified portion) to 0.2 div position.
4. Adjust VR6 (X74-1440) to position B trace to 10 div position (right end of the graticule scale) when rotated the DELAY TIME MULT control to 10.00 position.

## X position adjustment

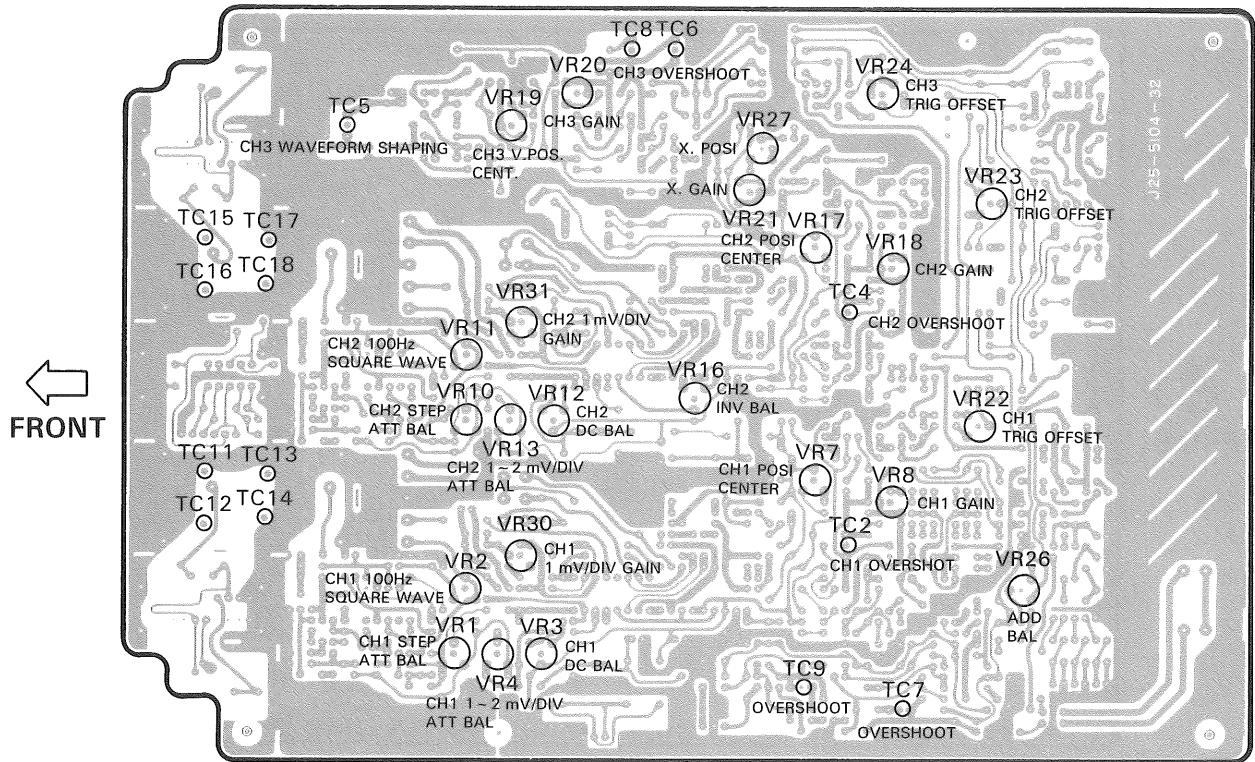
1. Select the vertical MODE switch to CH2 position and channel 2 AC-GND-DC switch to GND position.
2. Set the scope controls to display a trace to the graticule center.
3. Adjust VR27 (X73-1650) to position to trace to horizontal graticule when switched the HORIZ MODE switch to X-Y position.
4. Clockwise rotation of channel 2 position control should move up to 5 divisions upward and counterclockwise rotation should move up to 5 divisions downward.

## Calibration Voltage adjustment.

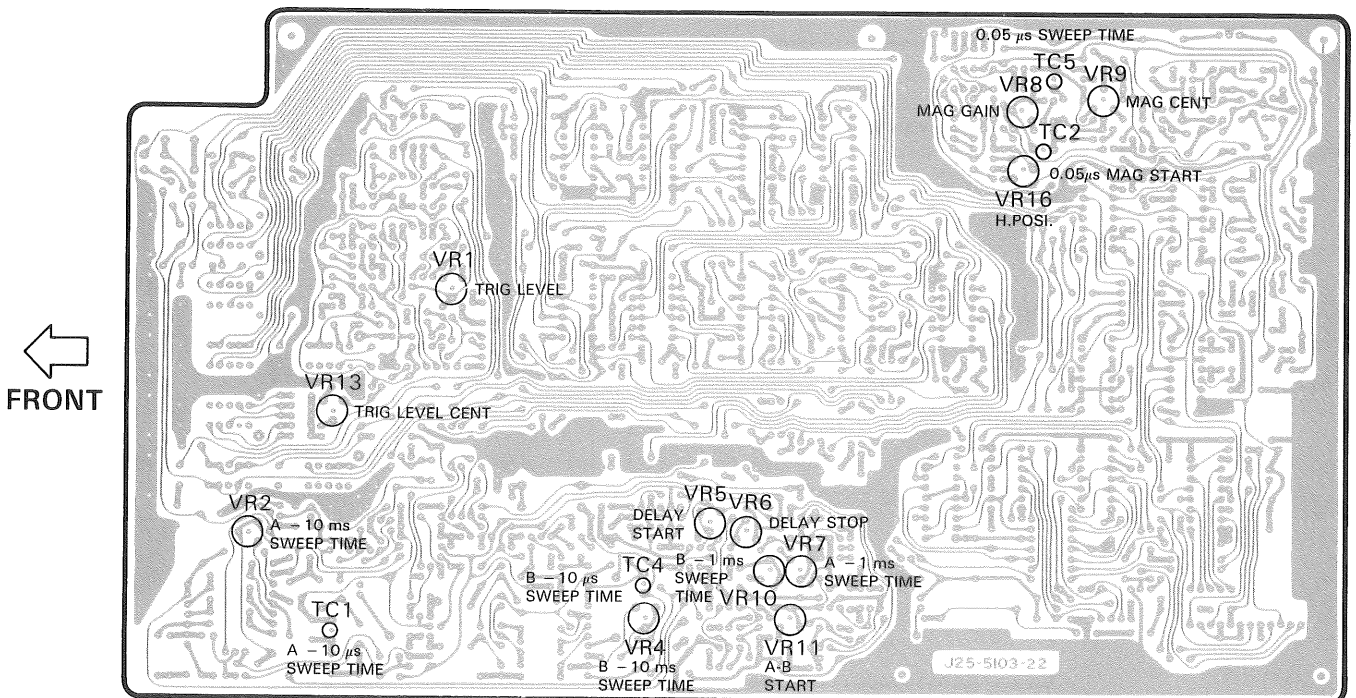
1. Apply a CAL signal to channel 1 input.
2. Adjust VR2 (X73-1660) for 0.5 division vertical amplitude.

# ADJUSTMENT

## VERTICAL PREAMP UNIT (X73-1650)

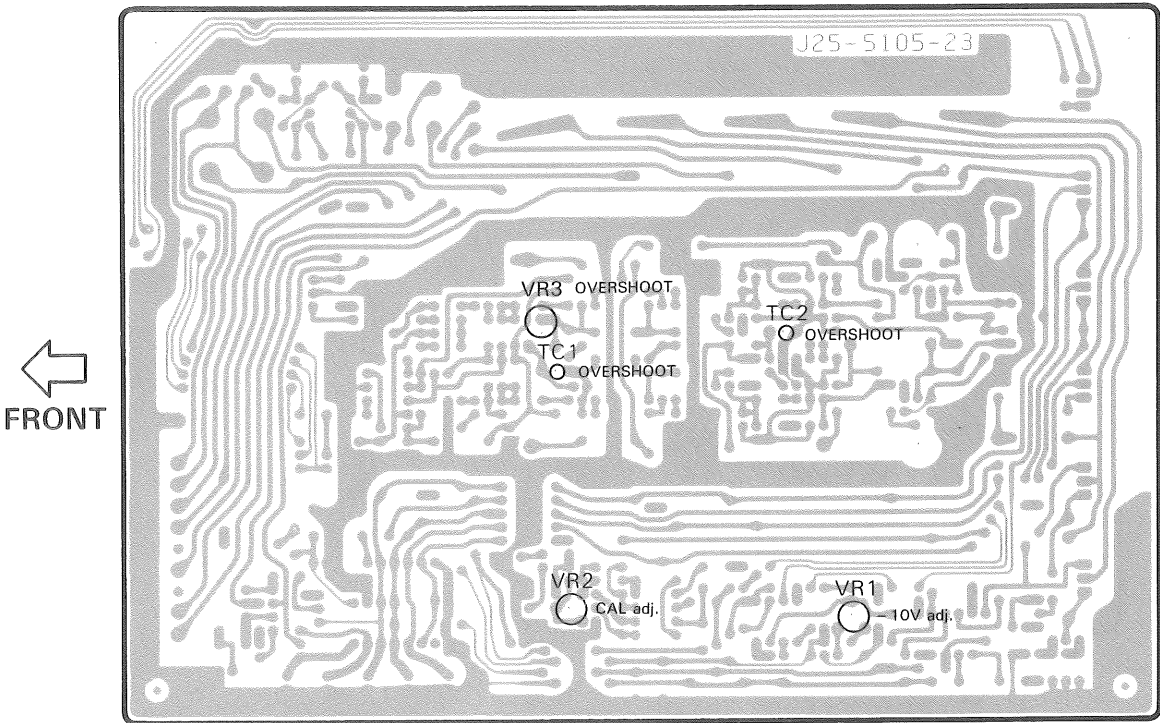


## SWEEP UNIT (X74-1440)

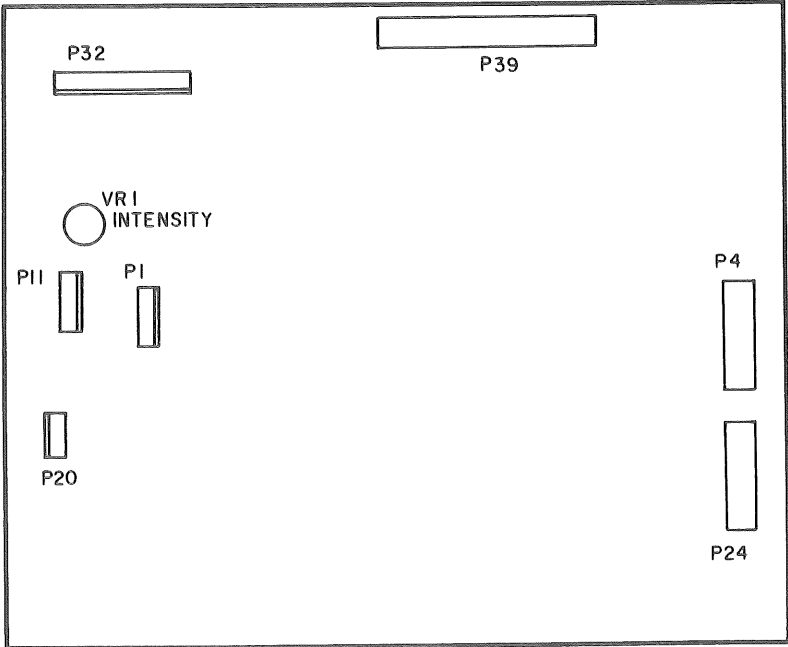


# ADJUSTMENT

## POWER & FINAL AMP UNIT (X73-1660)



## HIGH VOLTAGE UNIT (X68-1460)



# TROUBLESHOOTING

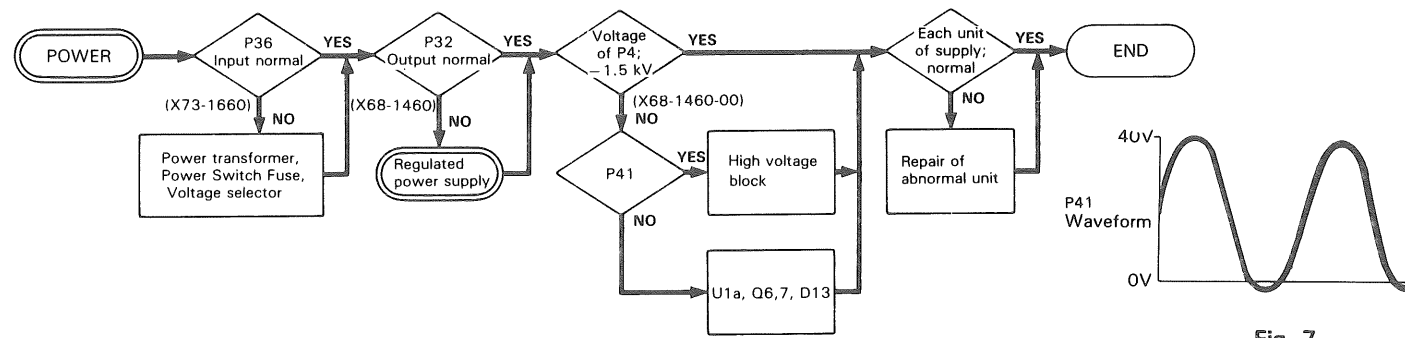
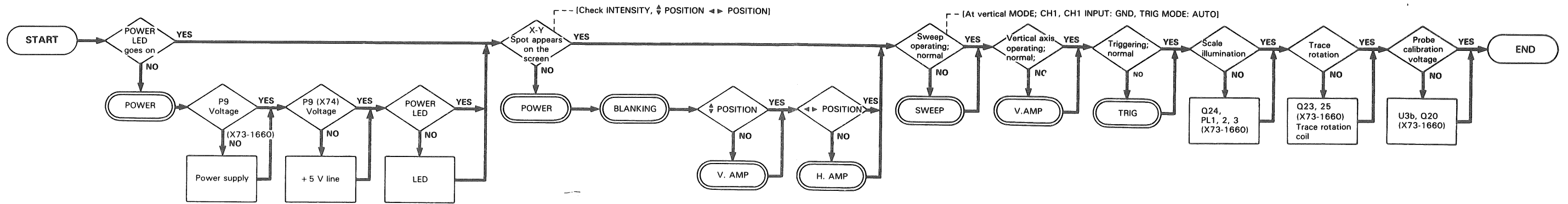


Fig. 7

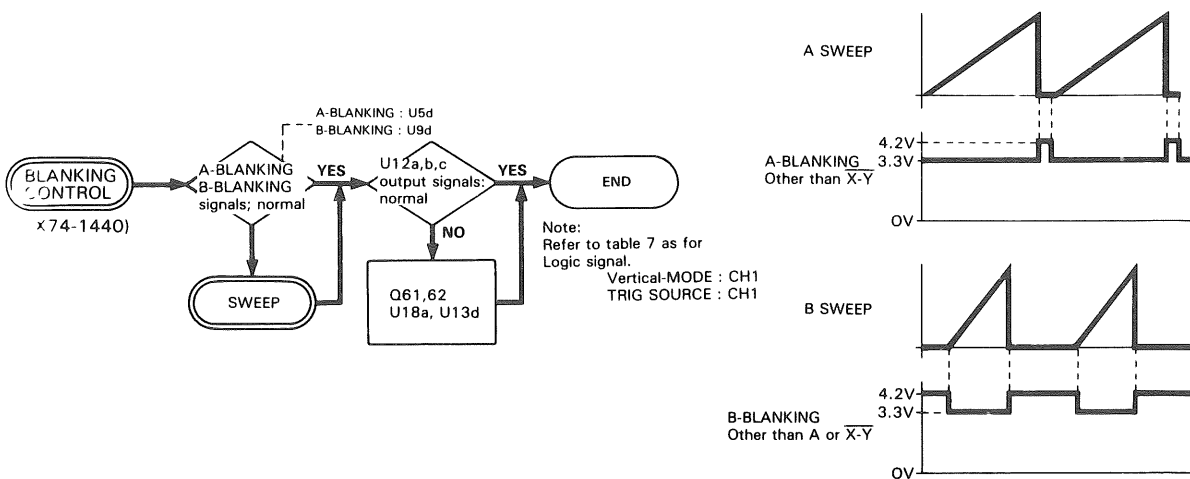
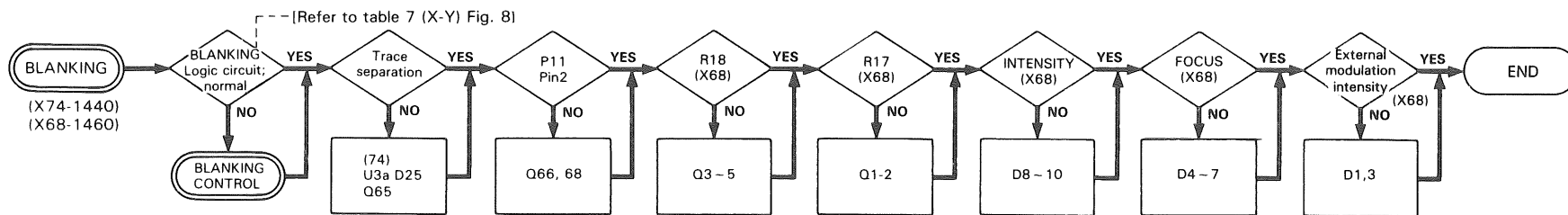


Fig. 9

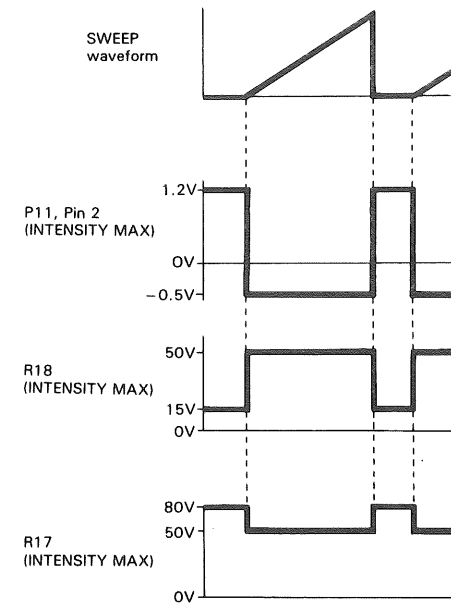
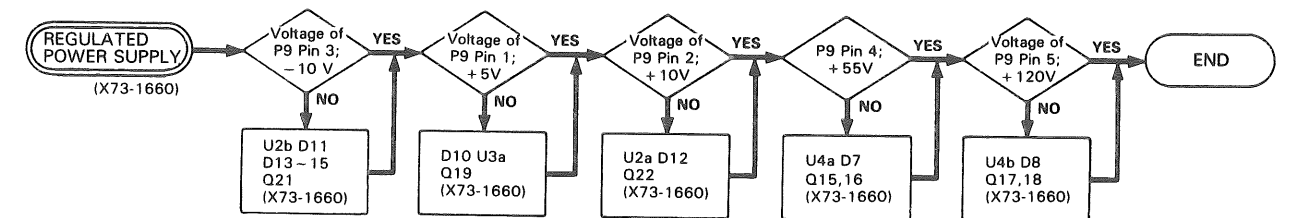
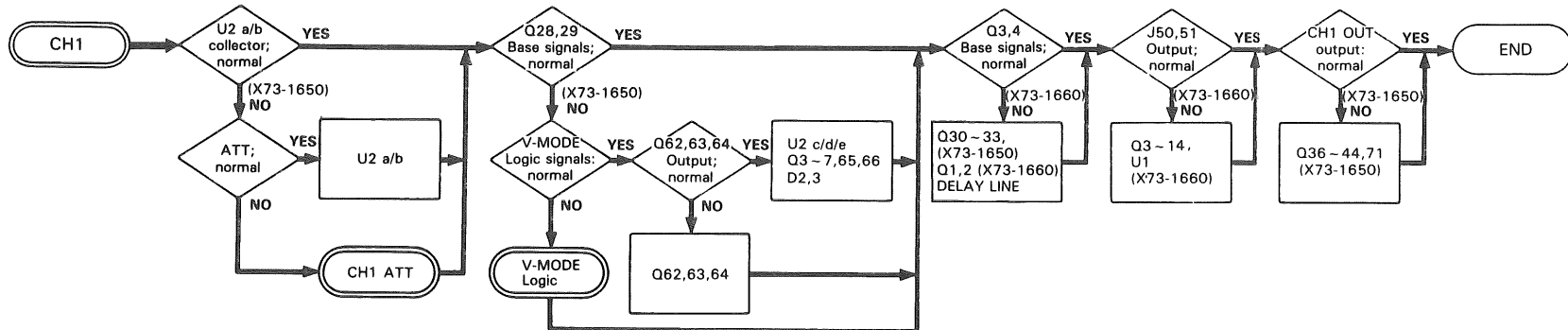
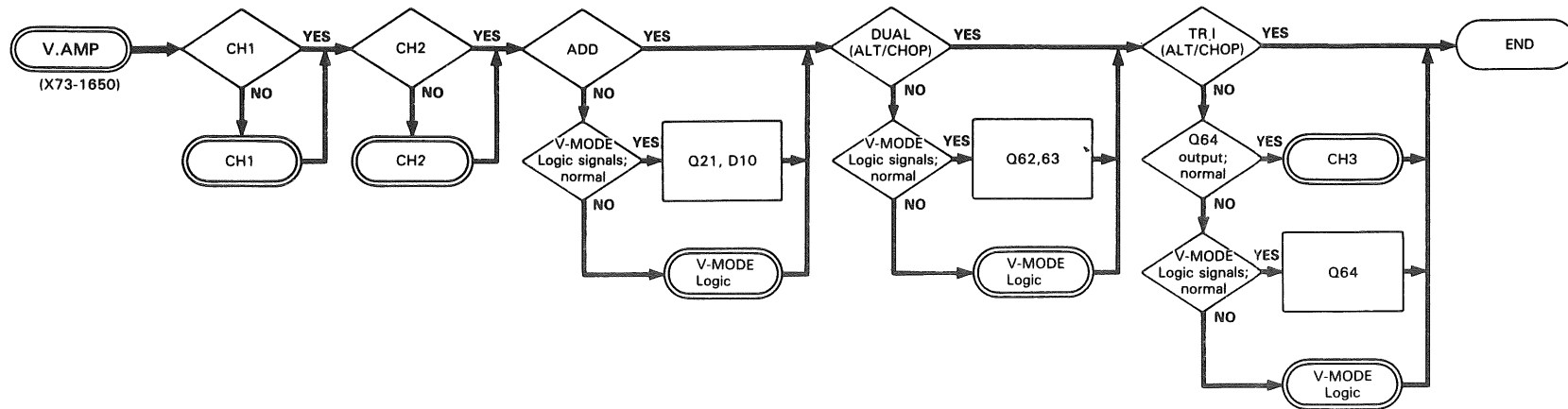


Fig. 8

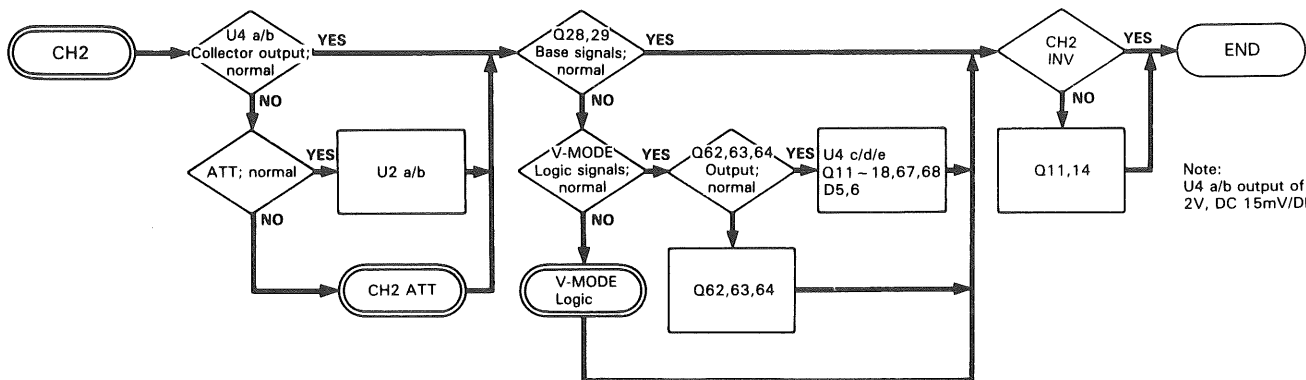
	U12						U18						
	Pin 8	Pin 12	Pin 6	Pin 9	Pin 10	Pin 11	Pin 1	Pin 2	Pin 3	Pin 4	Pin 4	Pin 15	Pin 1
A		H	H		H	H	L	L	L	H	L	H	
ALT						H				H	H	H	
B	H		H		L	H		H		L	H	L	
X-Y	H	L	H	L	H	H	H	H	H	L	L	L	L

Table 7

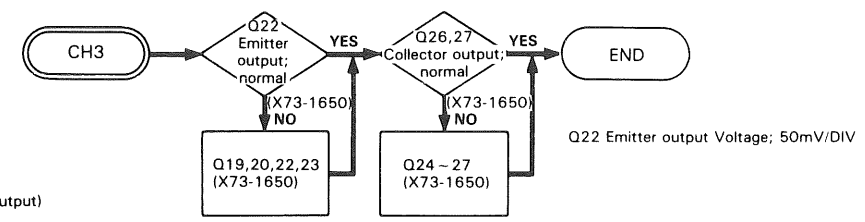
# TROUBLESHOOTING



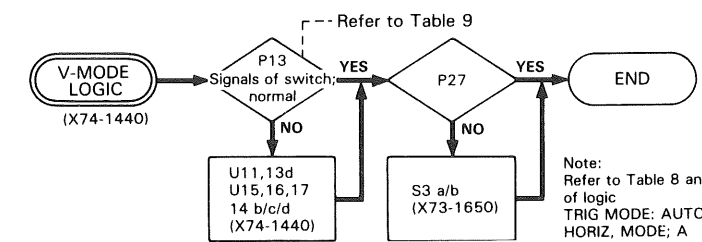
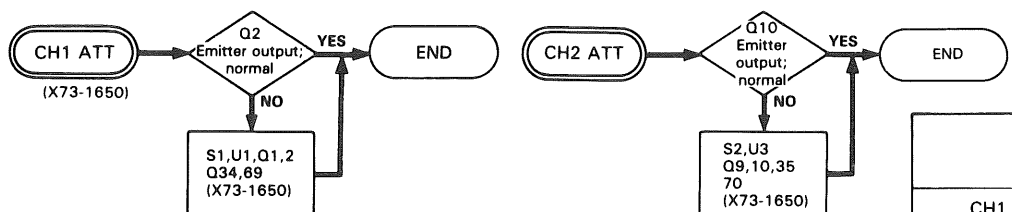
Note:  
 • U2 a/b collector output voltage  
 2V DC, 15mV/DIV (differential output)  
 • Q28,29 Base signals  
 3.6V DC, 100mV/DIV (differential output)  
 Q3,4 Base signals:  
 -3.5V DC, 200mV/DIV (differential output)  
 P50,51 output  
 37.4V DC, 4.6V/DIV (differential output)  
 CH1 OUT  
 AC coupling output  
 50mV/DIV (into 50Ω termination)



Note:  
 U4 a/b output of collector  
 2V, DC 15mV/DIV (differential output)



Q22 Emitter output Voltage; 50mV/DIV



Note:  
 Refer to Table 8 and 9 about signals  
 of logic  
 TRIG MODE: AUTO  
 HORIZ. MODE: A

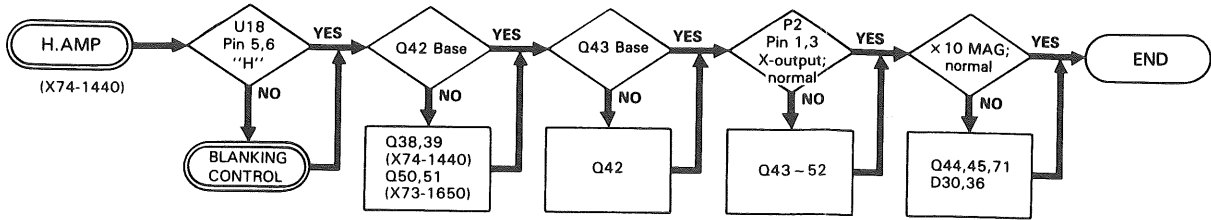
MODE	TRIPLE	
	ALT	CHOP
U4, Pin 1, 13 CK		
P11, pin 9 CH1-E		
P11, pin 7 CH2-E		
P11, pin 10 CH3-E		

Table 8

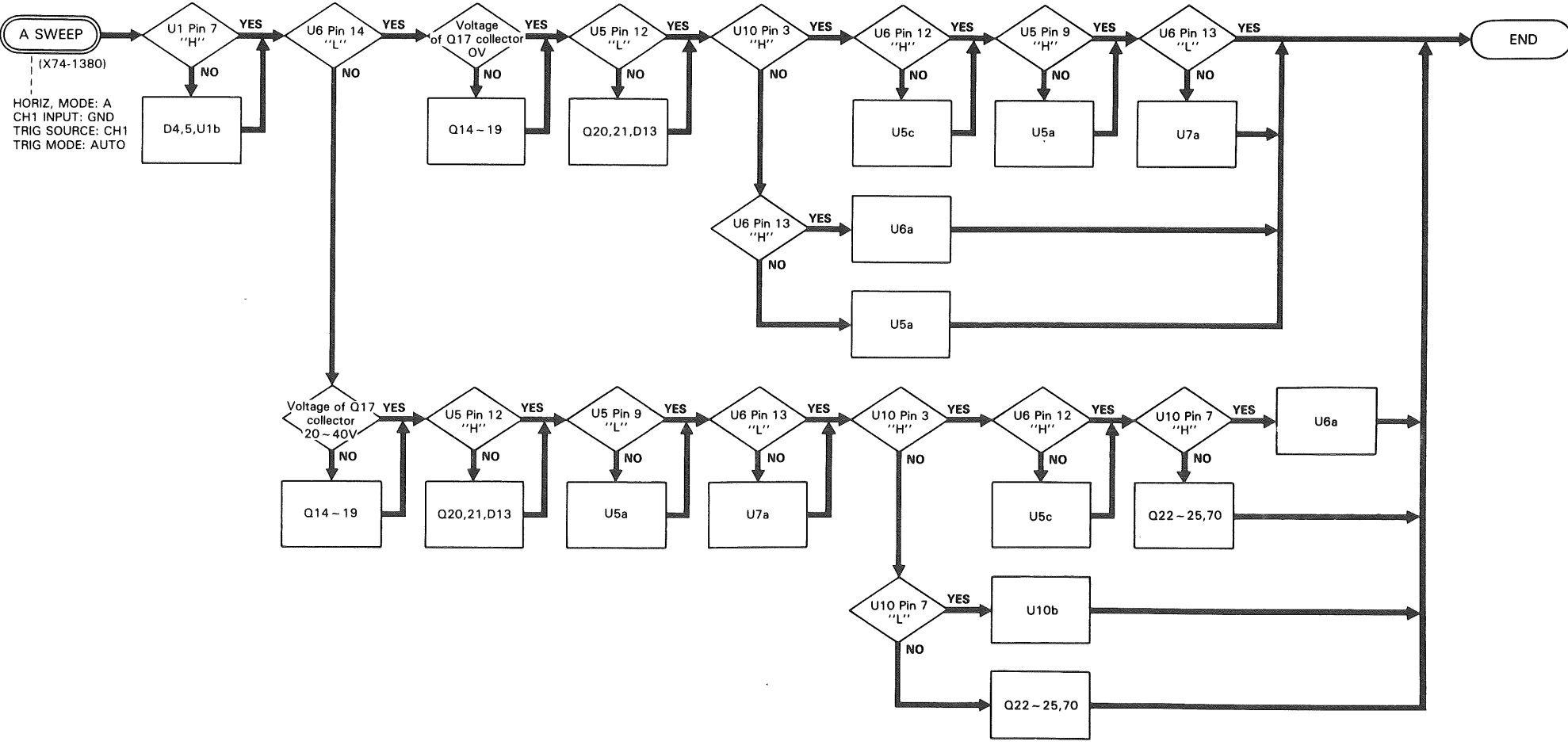
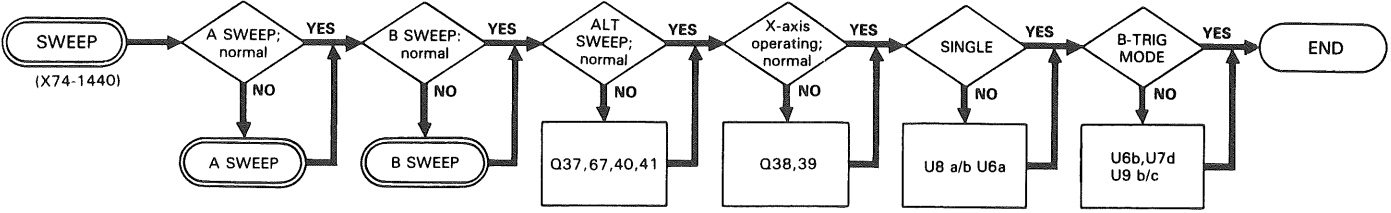
	P13 Pin 2 CH1	P13 Pin 3 CH2	P13 Pin 4 CH3	P13 Pin 5 ADD	U18 Pin 10	U11 Pin 6	U11 Pin 1	U15 Pin 3	U15 Pin 8	U17 Pin 6	U17 Pin 3	U14 Pin 3	U14 Pin 2	U17 Pin 4	P27 Pin 1	P27 Pin 2	P27 Pin 3	P27 Pin 4
CH1	L	H	H	H	L	H		L	L	H	H	L	H	L	L	H	H	L
CH2	H	L	H	H	L	L		L	H	L	H	L	H	L	L	H	L	H
ADD	L	L	H	L	L	H		L	L	L	H	-	H	L	-	H	L	L
DUAL	ALT			H	H	L			H	H	H	L	L	H	L	L	H	H
	CHOP			H	H	L			H	H	H	L	H	L	H	L	H	H
TRI	ALT			H	L			H	H	H	H	L	H	L	L	H	H	H
	CHOP			H	L			H	H	H	H	H	H	L	H	H	H	H
X-Y	L	H	H	H	H	H	L	L	L	H	H	L	L	H	L	H	-	-

Table 9

# TROUBLESHOOTING



Note:  
P2 Pin 1,3; 60V DC, 10V/DIV (differential output)







# PARTS LIST

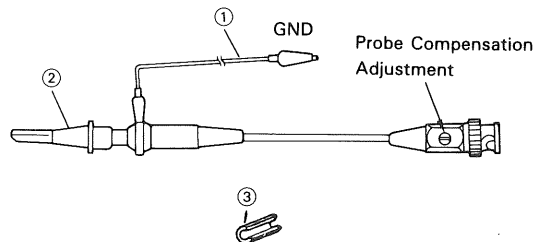
## MAIN CHASSIS

### Y70-1640-00

REF. NO	PARTS NO	NAME & DESCRIPTION
	B30-0952-05	LAMP (T4.2 8V 0.15A)
	B40-2765-04	NAME PLATE (SERIAL NO)
	B50-7673-00	INSTRUCTION MANUAL (JAPANESE)
	B50-7674-00	INSTRUCTION MANUAL (ENGLISH)
	E23-0552-04	EARTH TERMINAL
	E31-0564-05	WIRE ASS'Y (CRT SHIELD)
	E31-0717-05	WIRE ASS'Y (INLET GND)
	E31-2617-05	WIRE ASS'Y (J7 SINGLE LED)
	E31-2618-05	WIRE ASS'Y (J8 POWER LED)
	E31-2619-05	WIRE ASS'Y (J9 POWER H)
	E31-2620-05	WIRE ASS'Y (J10 TRIG)
	E31-2621-05	WIRE ASS'Y (J11 INTEN ASTIG9)
	E31-2622-05	WIRE ASS'Y (J12 POWER V)
	E31-2623-05	WIRE ASS'Y (J13 CH ENABLE)
	E31-2624-05	WIRE ASS'Y (J14 ILLUMI)
	E31-2625-05	WIRE ASS'Y (J15 DTM)
	E31-2626-05	WIRE ASS'Y (J16 CH3 IN)
	E31-2627-05	WIRE ASS'Y (J17 CH1 OUT)
	E31-2628-05	WIRE ASS'Y (J18 X-Y)
	E31-2629-05	WIRE ASS'Y (J19 PROBE ADJ.)
	E31-2630-05	WIRE ASS'Y (J20 Z IN)
	E31-2631-05	WIRE ASS'Y (J21 ROTATION)
	E31-2668-05	WIRE ASS'Y (FOCUS)
	E31-2678-05	WIRE ASS'Y (J32 HIGH VOLT)
	F05-1023-05	FUSE (6X30MM) 1A
	F05-6313-05	FUSE (5X20MM) 0.63AT
	F05-7011-05	FUSE (6X30MM) 0.7A
	F15-0741-14	FELT (20X12)
	F15-0742-14	FELT (20X20)
	F20-0658-04	INSULATED SHEET
	G16-0609-04	RUBBER SHEET
	H01-5892-04	CARTON BOX
	H10-2828-12	FOAMED STYRENE PAD (FRONT)
	H10-2829-12	FOAMED STYRENE PAD (REAR)
	H12-0564-04	PAD
	H20-1727-04	VINYL COVER
	J19-1620-05	CORD KEEP
	J61-0408-05	WIRE WRAPPING BAND
	J61-0522-05	WIRE WRAPPING BAND
	W03-2305-05	PROBE PC-39
C1	C91-1233-05	CAP. CERAMIC 6.8P 10% 50V
R1	RD14882E220J	RES. CARBON 22 5% 1/4W
R2	RD14882E220J	RES. CARBON 22 5% 1/4W
R3	RD14882E220J	RES. CARBON 22 5% 1/4W
1	BG4133S	LED (GREEN)
2	A01-1200-02	CASE (TOP)
3	A01-1201-02	CASE (BOTTOM)
4	A13-0904-22	FRAME (CENTER)
5	A13-0905-12	FRAME (R. UPPER)
6	A13-0906-12	FRAME (L)
7	A13-0912-02	FRAME (R. LOWER)
8	A20-2833-01	MOLDED PANEL
9	A21-1140-03	DECORATIVE PANEL
10	A22-0852-42	SUB PANEL
11	A23-1666-12	REAR PANEL
12	B07-0716-03	FILTER FRAME
13	B19-0749-04	FILTER
14	B30-0951-25	SCALE ILLUMI LAMP ASS'Y
15	B40-2912-03	NAME PLATE (MODEL)
16	B41-0710-04	CAUTION LABEL (HIGH VOLTAGE)
17	B41-0805-03	CAUTION LABEL
18	D19-0908-03	EXTENSION SHAFT
19	E04-0257-05	BNC RECEPTACLE
20A	E18-0365-05	AC SELECTOR WITH 6X30MM FUSE
20B	E18-0366-05	AC SELECTOR FOR 5X20MM FUSE
21	E21-0660-04	TERMINAL (CAL)
22	E21-0667-05	METAL TERMINAL
23	E23-0018-04	EARTH LUG
24	E23-0042-04	EARTH LUG
25	E23-0513-05	EARTH LUG (BNC)
26	E23-0561-14	G. TERMINAL
27A	E30-1818-05	JIS POWER CORD
27B	E30-1819-05	CEE POWER CORD
27C	E30-1821-05	SAA POWER CORD
27D	E30-1820-05	UL/CSA POWER CORD
27E	E30-1644-15	BS POWER CORD
28	F07-0908-14	PROTECTION COVER (HANDLE)
29	F10-1567-14	EARTH BAND (FOR H.V. BLOCK)
30	F10-1593-14	SHIELD PLATE
31	F11-0996-04	SHIELD CASE
32	F11-0998-03	SHIELD CASE
33	G01-0909-04	COIL SPRING (CAL SHIELD)
34	G02-0606-14	SPRING FOR HANDLE
35	J02-0089-05	FOOT

REF. NO	PARTS NO	NAME & DESCRIPTION
36	J10-0418-12	BEZEL
37	J19-1635-04	HOLDER FOR LED
38	J19-1644-13	CRT HOLDER
39	J19-1645-24	BRACKET
40	J19-1646-04	BRACKET
41	J21-2906-05	GEAR FOR HANDLE
42	J21-2907-05	RING FOR HANDLE
43	J21-4562-03	BRACKET FOR CRT
44	J31-0608-05	COLLAR
45	J42-0528-05	BUSHING
46	J59-0403-05	NYLON RIVET (ILLUMI)
47	J61-0049-05	WIRE BAND
48	K01-0524-15	HANDLE
49	K21-0892-03	KNOB (VOLTS/DIV)
50	K21-0895-03	KNOB (A SWEEP)
51	K21-0896-03	KNOB (B SWEEP)
52	K21-0897-14	KNOB
53	K23-0808-03	KNOB
54	K23-0809-03	KNOB
55	K27-0537-04	KNOB (FOR LEVER SWITCH)
56	L01-9526-05	POWER TRANSFORMER
57	L39-0524-05	COIL
58	L76-0110-05	DELAY LINE
59	N19-0725-04	PLATE FOR CRT HOLDER
60	R03-1509-05	V.R. 10K B
61	R05-8001-05	V.R. 3MB
62	R05-3505-05	V.R. (ROTATION) 20KB
63	R29-1502-15	V.R. WITH KNOB 100K
64	W01-0503-04	CORD WRAP
65	W02-0423-05	HIGH VOLTAGE POWER BLOCK
66	X68-1460-00	HIGH VOLTAGE UNIT
67	X73-1650-00	VERTICAL PREAMP UNIT
68	X73-1660-00	POWER & FINAL AMP UNIT
69	X74-1440-02	HOR. SWEEP UNIT
70	X81-1600-00	CRT SOCKET UNIT
71	150TTM31	CRT

## MODEL PC-39 (LOW CAPACITY PROBE)



ITEM	DESCRIPTION	PARTS NO.
①	Ground Wire Assembly	E30-1883-08
②	Retractable Hook Tip	E29-0540-08
③	Insulator Cap	B42-1950-08

# PARTS LIST

## HIGH VOLTAGE UNIT

### X68-1460-00

REF. NO	PARTS NO	NAME & DESCRIPTION
	F01-0813-05	HEAT SINK (CONVERTER)
	F15-0727-04	HOLDER (NEON LAMP)
	J25-5101-03	PCB (UNMOUNTED)
	N30-3006-46	SCREW, PAN HD M3X6
	R92-0150-05	JUMPING RES. ZERO OHM(10MM)
C001	CC45CH1H070D	CAP. CERAMIC 7P 0.5P 50V
C002	CC45CH1H120J	CAP. CERAMIC 12P 5% 50V
C003	CC45CH2H010C	CAP. CERAMIC 1P 0.25P 500V
C004	CC45CH2H010C	CAP. CERAMIC 1P 0.25P 500V
C005	CC45CH2H050C	CAP. CERAMIC 5P 0.25P 500V
C006	CC45CH2H010C	CAP. CERAMIC 1P 0.25P 500V
C007	CK45B2H472K	CAP. CERAMIC 4700P 10% 500V
C008	C90-0298-05	CAP. CERAMIC 0.1 20% 12V
C009	CK45B2H472K	CAP. CERAMIC 4700P 10% 500V
C010	C90-0298-05	CAP. CERAMIC 0.1 20% 12V
C011	C91-0571-05	CAP. CERAMIC 0.01 2KV
C012	NO USE	
C013	C91-0571-05	CAP. CERAMIC 0.01 2KV
C014	C91-0571-05	CAP. CERAMIC 0.01 2KV
C015	CE04W2E010M	CAP. ELECTRO 1 20% 250V
C016	C91-0571-05	CAP. CERAMIC 0.01 2KV
C017	C91-0571-05	CAP. CERAMIC 0.01 2KV
C018	C91-0571-05	CAP. CERAMIC 0.01 2KV
C019	CK45B2H102K	CAP. CERAMIC 1000P 10% 500V
C020	CK45E3D102P	CAP. CERAMIC 1000P 2KV
C021	CQ92FM1H154K	CAP. MYLAR 0.15 10% 50V
C022	CQ92FM1H154K	CAP. MYLAR 0.15 10% 50V
C023	NO USE	
C024	CQ92FM1H103K	CAP. MYLAR 0.01 10% 50V
C025	CK45B1H472K	CAP. CERAMIC 4700P 10% 50V
C026	C91-0571-05	CAP. CERAMIC 0.01 2KV
C027	C91-0571-05	CAP. CERAMIC 0.01 2KV
C028	CK45B2H102K	CAP. CERAMIC 1000P 10% 500V
C029	CK45B2H472K	CAP. CERAMIC 4700P 10% 500V
C030	CE04EW1E101M	CAP. ELECTRO 100 20% 25V
C031	CE04EW1E101M	CAP. ELECTRO 100 20% 25V
C032	CE04EW1E101M	CAP. ELECTRO 100 20% 25V
C033	CE04EW1E101M	CAP. ELECTRO 100 20% 25V
C034	CE04W2C3R3M	CAP. ELECTRO 3.3 20% 160V
C035	CK45B2H472K	CAP. CERAMIC 4700P 10% 500V
D001	1SS132	DIODE
D002	NO USE	
D003	1SS132	DIODE
D004	1SS83	DIODE
D005	1SS83	DIODE
D006	1SR35-200A	DIODE
D007	1SR35-200A	DIODE
D008	1SS83	DIODE
D009	1SS83	DIODE
D010	1SR35-200A	DIODE
D011	1SS132	DIODE
D012	1SS132	DIODE
D013	1SS132	DIODE
D014	1SR35-200A	DIODE
L001	L40-1011-13	FERRI INDUCTOR 100UH 10%
L002	L40-1011-13	FERRI INDUCTOR 100UH 10%
NL001	NE-2B	NEON LAMP
NL002	NE-2B	NEON LAMP
NL003	NE-2B	NEON LAMP
NL004	NE-2B	NEON LAMP
P001	E40-0373-05	PIN CONNECTOR 3P
P004	E40-0332-05	PIN CONNECTOR 3P
P011	E40-0373-05	PIN CONNECTOR 3P
P020	E40-0273-05	PIN CONNECTOR 2P
P024	E40-0332-05	PIN CONNECTOR 3P
P032	E40-0873-05	PIN CONNECTOR 8P
P039	E40-0703-05	PIN CONNECTOR 7P
Q001	2SA1208(S)	TR. SI, PNP
Q002	2SC2910(S)	TR. SI, NPN
Q003	2SA1210(S)	TR. SI, PNP
Q004	2SA1005(K,L)	TR. SI, PNP
Q005	2SC2912(S)	TR. SI, NPN
Q006	2SA1175(F)	TR. SI, PNP

REF. NO	PARTS NO	NAME & DESCRIPTION
Q007	2SD613(E)	TR. SI, NPN
Q008	2SC2271(D)	TR. SI, NPN
R001	RD140B2H103J	RES. CARBON 10K 5% 1/2W
R002	RD140B2C332J	RES. CARBON 3.3K 5% 1/6W
R003	RD140B2C102J	RES. CARBON 1K 5% 1/6W
R004	RD140B2C203J	RES. CARBON 20K 5% 1/6W
R005	RD140B2E683J	RES. CARBON 68K 5% 1/4W
R006	RD140B2E683J	RES. CARBON 68K 5% 1/4W
R007	RD140B2E683J	RES. CARBON 68K 5% 1/4W
R008	RD140B2C152J	RES. CARBON 1.5K 5% 1/6W
R009	RD140B2C124J	RES. CARBON 120K 5% 1/6W
R010	RD140B2C332J	RES. CARBON 3.3K 5% 1/6W
R011	RD140B2C751J	RES. CARBON 750 5% 1/6W
R012	RD140B2C104J	RES. CARBON 100K 5% 1/6W
R013	RD140B2C124J	RES. CARBON 120K 5% 1/6W
R014	RD140B2C332J	RES. CARBON 3.3K 5% 1/6W
R015	RD140B2C752J	RES. CARBON 7.5K 5% 1/6W
R016	RD140B2C102J	RES. CARBON 1K 5% 1/6W
R017	RD140B2E470J	RES. CARBON 47 5% 1/4W
R018	RD140B2E470J	RES. CARBON 47 5% 1/4W
R019	RD140B2E334J	RES. CARBON 330K 5% 1/4W
R020	R92-1034-05	RES. METAL FILM 47M 5% 1/2W
R021	RD140B2E334J	RES. CARBON 330K 5% 1/4W
R022	R92-1034-05	RES. METAL FILM 47M 5% 1/2W
R023	R92-1165-05	RES. FIXED 6.8M 5% 1W
R024	R92-1154-05	RES. FIXED 11M 5% 1W
R029	RN14BK2C1003F	RES. METAL FILM 100K 1% 1/6W
R030	R92-1125-05	RES. METAL FILM 7.5M 1% 1W
R031	R92-1125-05	RES. METAL FILM 7.5M 1% 1W
R035	RD140B2E104J	RES. CARBON 100K 5% 1/4W
R036	NO USE	
R037	RD140B2E102J	RES. CARBON 1K 5% 1/4W
R038	RD140B2C562J	RES. CARBON 5.6K 5% 1/6W
R039	RD140B2C101J	RES. CARBON 100 5% 1/6W
R040	RD140B2C563J	RES. CARBON 56K 5% 1/6W
R041	RD140B2C563J	RES. CARBON 56K 5% 1/6W
R042	RD140B2C133J	RES. CARBON 13K 5% 1/6W
R043	RD140B2C273J	RES. CARBON 27K 5% 1/6W
R044	RD140B2E104J	RES. CARBON 100K 5% 1/4W
U001	NJM4558D	IC, OP AMP
VR001	R12-5525-05	RES. SEMI FIXED 100K B

## VERTICAL PREAMPLIFIER UNIT

### X73-1650-00

REF. NO	PARTS NO	NAME & DESCRIPTION
	F10-1588-04	SHIELD PLATE(FOR C3,R1)
	F10-1589-04	SHIELD PLATE(FOR C23,R71)
	F10-1590-14	SHIELD PLATE
	F10-1591-04	SHIELD PLATE(FOR ATT.FOOT SIDE)
	J25-5104-32	PCB (UNMOUNTED)
	J30-0620-04	SPACER
	J61-0408-05	WIRE WRAPPING BAND
	S02-4504-25	ROTARY SWITCH
C001	C91-0502-05	CAP. METAL FILM 0.01 20% 630V
C002	C91-0769-05	CAP. AXIAL 0.01 20% 16V
C003	C91-0501-05	CAP. METAL FILM 0.047 10% 630V
C004	CC45FCH1H330J	CAP. CERAMIC 33P 5% 50V
C005	CQ92FM1H102K	CAP. MYLAR 1000P 10% 50V
C006	CE04BW1E220M	CAP. ELECTRO 22 20% 25V
C007	NO USE	
C008	C91-0769-05	CAP. AXIAL 0.01 20% 16V
C009	C91-0769-05	CAP. AXIAL 0.01 20% 16V
C010	CE04EW1C330M	CAP. ELECTRO 33 20% 16V
C011	C91-0769-05	CAP. AXIAL 0.01 20% 16V
C012	CE04EW1C330M	CAP. ELECTRO 33 20% 16V
C013	NO USE	
C014	CE04EW1C330M	CAP. ELECTRO 33 20% 16V
C015	CE04EW1C330M	CAP. ELECTRO 33 20% 16V
C016	CE04EW1C330M	CAP. ELECTRO 33 20% 16V
C017	C91-0769-05	CAP. AXIAL 0.01 20% 16V
C018	C91-0769-05	CAP. AXIAL 0.01 20% 16V
C019	NO USE	
C020	C91-1227-05	CAP. CERAMIC 3P 0.25P 3KV
C021	C91-0502-05	CAP. METAL FILM 0.01 20% 630V
C022	C91-0769-05	CAP. AXIAL 0.01 20% 16V
C023	C91-0501-05	CAP. METAL FILM 0.047 10% 630V
C024	CC45FCH1H330J	CAP. CERAMIC 33P 5% 50V
C025	CQ92FM1H102K	CAP. MYLAR 1000P 10% 50V
C026	CE04BW1E220M	CAP. ELECTRO 22 20% 25V
C027	C91-0769-05	CAP. AXIAL 0.01 20% 16V

# PARTS LIST

REF.NO	PARTS NO	NAME & DESCRIPTION	REF.NO	PARTS NO	NAME & DESCRIPTION
C028	CE04EW1C330M	CAP. ELECTRO 33 20% 16V	D001	1S1544A	DIODE
C029	C91-0769-05	CAP. AXIAL 0.01 20% 16V	D002	1SS132	DIODE
C030	CE04EW1C330M	CAP. ELECTRO 33 20% 16V	D003	1SS132	DIODE
C031	CE04EW1C330M	CAP. ELECTRO 33 20% 16V	D004	1S1544A	DIODE
C032	CE04EW1C330M	CAP. ELECTRO 33 20% 16V	D005	1SS132	DIODE
C033	C91-0769-05	CAP. AXIAL 0.01 20% 16V	D006	1SS132	DIODE
C034	CE04EW1C330M	CAP. ELECTRO 33 20% 16V	D007	MT25.1JB	DIODE, ZENER 5.0V
C035	C91-0769-05	CAP. AXIAL 0.01 20% 16V	D008	1SS132	DIODE
C036	NO USE		D009	1SS132	DIODE
C037	C91-0769-05	CAP. AXIAL 0.01 20% 16V	D010	MT27.5JC	DIODE, ZENER 7.5V
C038	C91-0502-05	CAP. METAL FILM 0.01 20% 630V	D011	1SS132	DIODE
C039	C91-0769-05	CAP. CERAMIC 0.01 20% 16V	D012	MT25.1JB	DIODE, ZENER 5.0V
C040	CC45CH1H101J	CAP. CERAMIC 100P 5% 50V	D013	MT25.1JB	DIODE, ZENER 5.0V
C041	C91-0769-05	CAP. AXIAL 0.01 20% 16V	D014	1SS132	DIODE
C042	NO USE		D015	1S1544A	DIODE
C043	CE04EW1C330M	CAP. ELECTRO 33 20% 16V	D016	1SS132	DIODE
C044	CC45CH1HOR5C	CAP. CERAMIC 0.5P 0.25P 50V	D017	1SS132	DIODE
C045	CC45CH1HOR5C	CAP. CERAMIC 0.5P 0.25P 50V	D018	MT25.1JB	DIODE, ZENER 5.0V
C046	CE04BW1E220M	CAP. ELECTRO 22 20% 25V	D019	MT25.1JB	DIODE, ZENER 5.0V
C047	C91-1227-05	CAP. CERAMIC 3P 0.25P 3KV	D020	1SS132	DIODE
C048	CC45CH1H070D	CAP. CERAMIC 7P 0.5P 50V	D021	1SS132	DIODE
C049	CC45CH1H070D	CAP. CERAMIC 7P 0.5P 50V	J006	E31-2616-05	LEAD WIRE WITH CONNECTOR
C050	C91-1227-05	CAP. CERAMIC 3P 0.25P 3KV	J027	E31-2672-05	LEAD WIRE WITH CONNECTOR
C051	C91-1232-05	CAP. CERAMIC 5.6P 10% 50V	J028	E31-2673-05	LEAD WIRE WITH CONNECTOR
C052	NO USE		J029	E31-2675-15	LEAD WIRE WITH CONNECTOR
C053	C91-1227-05	CAP. CERAMIC 3P 0.25P 3KV	J030	E31-2676-05	LEAD WIRE WITH CONNECTOR
C054	C91-1227-05	CAP. CERAMIC 3P 0.25P 3KV	J033	E31-2698-15	LEAD WIRE WITH CONNECTOR
C055	CE04EW1C330M	CAP. ELECTRO 33 20% 16V	J062	E31-2673-05	LEAD WIRE WITH CONNECTOR
C056	CE04EW1C330M	CAP. ELECTRO 33 20% 16V	J063	E31-2675-15	LEAD WIRE WITH CONNECTOR
C059	CE04BW1E220M	CAP. ELECTRO 22 20% 25V	J064	E31-2698-15	LEAD WIRE WITH CONNECTOR
C060	CE04EW1C330M	CAP. ELECTRO 33 20% 16V	J065	E31-2698-15	LEAD WIRE WITH CONNECTOR
C061	CE04EW1C330M	CAP. ELECTRO 33 20% 16V	P010	E40-0273-05	PIN CONNECTOR 2P
C062	CE04EW1C330M	CAP. ELECTRO 33 20% 16V	P011	NO USE	
C063	CE04EW1C101M	CAP. ELECTRO 100 20% 16V	P012	E40-0374-05	PIN CONNECTOR 3P
C064	CE04EW1C101M	CAP. ELECTRO 100 20% 16V	P013	E40-0573-05	PIN CONNECTOR 5P
C065	C91-0769-05	CAP. AXIAL 0.01 20% 16V	P016	E40-0273-05	PIN CONNECTOR 2P
C066	C91-0769-05	CAP. AXIAL 0.01 20% 16V	P017	E40-0273-05	PIN CONNECTOR 2P
C067	CC45CH1H090D	CAP. CERAMIC 9P 0.5P 50V	P018	E40-0273-05	PIN CONNECTOR 2P
C068	CC45CH1H090D	CAP. CERAMIC 9P 0.5P 50V	P028	E40-0574-05	PIN CONNECTOR 5P
C071	C91-1223-05	CAP. CERAMIC 3P 0.25P 3KV	P029	E40-0674-05	PIN CONNECTOR 6P
C072	CC45CH1H470J	CAP. CERAMIC 47P 5% 50V	P030	E40-0373-05	PIN CONNECTOR 3P
C073	C092FM1H104K	CAP. MYLAR 0.1 10% 50V	P042	E40-0312-05	PIN CONNECTOR 3P
C074	C91-1234-05	CAP. CERAMIC 3P 0.25P 3KV	P056	E40-0273-05	PIN CONNECTOR 2P
C075	CC45CH1H330J	CAP. CERAMIC 33P 5% 50V	P057	E40-0273-05	PIN CONNECTOR 2P
C076	CC45CH1H330J	CAP. CERAMIC 33P 5% 50V	P058	E40-0273-05	PIN CONNECTOR 2P
C077	CC45CH1H330J	CAP. CERAMIC 33P 5% 50V	P059	E40-0273-05	PIN CONNECTOR 2P
C078	CE04BW1E220M	CAP. ELECTRO 22 20% 25V	P060	E40-0273-05	PIN CONNECTOR 2P
C079	C91-0745-05	CAP. CERAMIC 3P 0.25P 3KV	Q001	2SK304(F)	FET, N-CHANNEL
C080	C91-0745-05	CAP. CERAMIC 3P 0.25P 3KV	Q002	2SC3315(D)	TR. SI, NPN
C081	C91-0745-05	CAP. CERAMIC 3P 0.25P 3KV	Q003	2SA1005(K)	TR. SI, PNP
C082	CE04DWOJ222M	CAP. ELECTRO 2200 20% 6.3V	Q004	2SA1005(K)	TR. SI, PNP
C083	CE04DWOJ222M	CAP. ELECTRO 2200 20% 6.3V	Q005	2SC3354(T,S)	TR. SI, NPN
C084	C092M1H104K	CAP. MYLAR 0.1 10% 50V	Q006	2SC3354(T,S)	TR. SI, NPN
C085	C092M1H104K	CAP. MYLAR 0.1 10% 50V	Q007	2SC3354(T,S)	TR. SI, NPN
C086	C91-0769-05	CAP. AXIAL 0.01 20% 16V	Q008	2SC3354(T,S)	TR. SI, NPN
C087	C91-0769-05	CAP. AXIAL 0.01 20% 16V	Q009	2SK304(F)	FET, N-CHANNEL
C088	C91-0769-05	CAP. AXIAL 0.01 20% 16V	Q010	2SC3315(D)	TR. SI, NPN
C089	CE04EW1C330M	CAP. ELECTRO 33 20% 16V	Q011	2SA1005(K)	TR. SI, PNP
C090	CE04EW1C330M	CAP. ELECTRO 33 20% 16V	Q012	2SA1005(K)	TR. SI, PNP
C091	NO USE		Q013	2SA1005(K)	TR. SI, PNP
C092	C91-0769-05	CAP. AXIAL 0.01 20% 16V	Q014	2SA1005(K)	TR. SI, PNP
C095	CE04EW1C330M	CAP. ELECTRO 33 20% 16V	Q015	2SC3354(T,S)	TR. SI, NPN
C096	C91-0769-05	CAP. AXIAL 0.01 20% 16V	Q016	2SC3354(T,S)	TR. SI, NPN
C097	C91-0769-05	CAP. AXIAL 0.01 20% 16V	Q017	2SC3354(T,S)	TR. SI, NPN
C098	CE04EW1C330M	CAP. ELECTRO 33 20% 16V	Q018	2SC3354(T,S)	TR. SI, NPN
C101	CE04EW1C221M	CAP. ELECTRO 220 20% 16V	Q019	2SK304(F)	FET, N-CHANNEL
C102	CE04EW1C221M	CAP. ELECTRO 220 20% 16V	Q020	2SK304(F)	FET, N-CHANNEL
C103	CE04EW1C221M	CAP. ELECTRO 220 20% 16V	Q021	2SA1005(K)	TR. SI, PNP
C104	C91-0769-05	CAP. AXIAL 0.01 20% 16V	Q022	2SC3315(D)	TR. SI, NPN
C105	CC45CH1H050C	CAP. CERAMIC 5P 0.25P 50V	Q023	2SC3315(D)	TR. SI, NPN
C106	CE04EW1C330M	CAP. ELECTRO 33 20% 16V	Q024	2SC3354(T,S)	TR. SI, NPN
C107	C91-0742-05	CAP. CERAMIC 75P 10% 50V	Q025	2SC3354(T,S)	TR. SI, NPN
C108	C91-0742-05	CAP. CERAMIC 75P 10% 50V	Q026	2SC3354(T,S)	TR. SI, NPN
C109	C91-1223-05	CAP. CERAMIC 3P 0.25P 3KV	Q027	2SC3354(T,S)	TR. SI, NPN
C110	NO USE		Q028	2SC3315(D)	TR. SI, NPN
C111	CC45CH1H100D	CAP. CERAMIC 10P 0.5P 50V	Q029	2SC3315(D)	TR. SI, NPN
C112	NO USE		Q030	2SA1206	TR. SI, PNP
C113	C91-1227-05	CAP. CERAMIC 3P 0.25P 3KV			
C114	CC45CH1H100D	CAP. CERAMIC 10P 0.5P 50V			
C115	C91-1230-05	CAP. CERAMIC 3P 0.25P 3KV			
C801	CC45SL1H331J	CAP. CERAMIC 330P 5% 50V			

# PARTS LIST

REF.NO	PARTS NO	NAME & DESCRIPTION
Q031	2SA1206	TR. SI, PNP
Q032	2SC2644	TR. SI, NPN
Q033	2SC2644	TR. SI, NPN
Q034	2SK184(Y)	FET, N-CHANNEL
Q035	2SK184(Y)	FET, N-CHANNEL
Q036	2SC3315(D)	TR. SI, NPN
Q037	2SC3315(D)	TR. SI, NPN
Q038	2SA1005(K)	TR. SI, PNP
Q039	2SA1005(K)	TR. SI, PNP
Q040	2SA1005(K)	TR. SI, PNP
Q041	2SA1005(K,L)	TR. SI, PNP
Q042	2SC3354(T,S)	TR. SI, NPN
Q043	2SC3354(T,S)	TR. SI, NPN
Q044	2SC1973	TR. SI, NPN
Q045	2SC3315(D)	TR. SI, NPN
Q046	2SC3315(D)	TR. SI, NPN
Q047	2SA1005(K)	TR. SI, PNP
Q048	2SA1005(K)	TR. SI, PNP
Q049	2SA1005(K)	TR. SI, PNP
Q050	2SC2785(F)	TR. SI, NPN
Q051	2SC2785(F)	TR. SI, NPN
Q052	2SC3315(D)	TR. SI, NPN
Q053	2SC3315(D)	TR. SI, NPN
Q054	2SA1005(K)	TR. SI, PNP
Q055	2SA1005(K)	TR. SI, PNP
Q056	2SA1005(K)	TR. SI, PNP
Q057	2SA1175(F)	TR. SI, PNP
Q058	2SA1175(F)	TR. SI, PNP
Q059	2SA1005(K)	TR. SI, PNP
Q060	2SC3354(T,S)	TR. SI, NPN
Q061	2SC3354(T,S)	TR. SI, NPN
Q062	2SC2785(F)	TR. SI, NPN
Q063	2SC2785(F)	TR. SI, NPN
Q064	2SC2785(F)	TR. SI, NPN
Q065	2SC3315(D)	TR. SI, NPN
Q066	2SC3315(D)	TR. SI, NPN
Q067	2SC3315(D)	TR. SI, NPN
Q068	2SC3315(D)	TR. SI, NPN
Q069	2SK304(F)	FET, N-CHANNEL
Q070	2SK304(F)	FET, N-CHANNEL
Q071	2SA1005(K)	TR. SI, PNP
R001	RD148B2C105J	RES. CARBON 1M 5% 1/6W
R002	RD148B2E330J	RES. CARBON 33 5% 1/4W
R003	RD14CB2C684J	RES. CARBON 680K 5% 1/6W
R004	RD148B2C220J	RES. CARBON 22 5% 1/6W
R005	RN148K2C5003F	RES. METAL FILM 500K 1% 1/6W
R006	RN148K2E5003F	RES. METAL FILM 500K 1% 1/4W
R007	RD148B2C684J	RES. CARBON 680K 5% 1/6W
R008	RD148B2E105J	RES. CARBON 1M 5% 1/4W
R009	RD148B2E162J	RES. CARBON 1.6K 5% 1/4W
R010	RD148B2C100J	RES. CARBON 10 5% 1/6W
R011	RD148B2C103J	RES. CARBON 10K 5% 1/6W
R012	RD148B2E132J	RES. CARBON 1.3K 5% 1/4W
R013	RD148B2C101J	RES. CARBON 100 5% 1/6W
R014	RD148B2C101J	RES. CARBON 100 5% 1/6W
R015	RD148B2C100J	RES. CARBON 10 5% 1/6W
R016	RD148B2C331J	RES. CARBON 330 5% 1/6W
R017	RD148B2C101J	RES. CARBON 100 5% 1/6W
R018	RD148B2C751J	RES. CARBON 750 5% 1/6W
R019	RD148B2C181J	RES. CARBON 180 5% 1/6W
R020	RN148K2C30ROF	RES. METAL FILM 30.0 1% 1/6W
R021	NO USE	
R022	RD148B2C621J	RES. CARBON 620 5% 1/6W
R023	RD148B2C270J	RES. CARBON 27 5% 1/6W
R024	R92-1162-05	RES. METAL FILM 560 5% 1/8W
R025	RN148K2E1800F	RES. METAL FILM 180 1% 1/4W
R026	RD148B2C271J	RES. CARBON 270 5% 1/6W
R027	NO USE	
R028	RD148B2C470J	RES. CARBON 47 5% 1/6W
R029	RD148B2C560J	RES. CARBON 56 5% 1/6W
R030	RD148B2E104J	RES. CARBON 100K 5% 1/4W
R031	RN148K2E1801F	RES. METAL FILM 1.8K 1% 1/4W
R032	RN148K2E1801F	RES. METAL FILM 1.8K 1% 1/4W
R033	RN148K2C2700F	RES. METAL FILM 270 1% 1/6W
R034	RN148K2C12ROF	RES. METAL FILM 12.0 1% 1/6W
R035	RN148K2E1601F	RES. METAL FILM 1.6K 1% 1/4W
R036	RN148K2E1601F	RES. METAL FILM 1.6K 1% 1/4W
R037	RN148K2E3900F	RES. METAL FILM 390 1% 1/4W
R038	RD148B2E101J	RES. CARBON 100 5% 1/4W
R039	RD148B2E101J	RES. CARBON 100 5% 1/4W
R040	RN148K2E7500F	
R041	RN148K2E7500F	
R042	RN148K2E5101F	RES. METAL FILM 5.1K 1% 1/4W
R043	RN148K2E4700F	RES. METAL FILM 470 1% 1/4W
R044	RN148K2E3001F	RES. METAL FILM 3K 1% 1/4W
R045	RN148K2E7500F	
R046	RN148K2E7500F	

REF.NO	PARTS NO	NAME & DESCRIPTION
R047	RD148B2C220J	RES. CARBON 22 5% 1/6W
R048	RD148B2C220J	RES. CARBON 22 5% 1/6W
R049	RN148K2E1002F	RES. METAL FILM 10K 1% 1/4W
R050	RN148K2C3001F	RES. METAL FILM 3K 1% 1/6W
R051	RD148B2E101J	RES. CARBON 100 5% 1/4W
R052	RD148B2E101J	RES. CARBON 100 5% 1/4W
R053	RN148K2C9100F	RES. METAL FILM 910 1% 1/6W
R054	RN148K2C9100F	RES. METAL FILM 910 1% 1/6W
R055	RN148K2C8200F	RES. METAL FILM 820 1% 1/6W
R056	RN148K2C8200F	RES. METAL FILM 820 1% 1/6W
R057	RD148B2E470J	RES. CARBON 47 5% 1/4W
R058	RD148B2E470J	RES. CARBON 47 5% 1/4W
R059	RN148K2E6800F	RES. METAL FILM 680 1% 1/4W
R060	RN148K2E6800F	RES. METAL FILM 680 1% 1/4W
R061	RN148K2E8200F	RES. METAL FILM 820 1% 1/4W
R062	RD148B2E272J	RES. CARBON 2.7K 5% 1/4W
R063	RD148B2C272J	RES. CARBON 2.7K 5% 1/6W
R064	RD148B2E101J	RES. CARBON 100 5% 1/4W
R065	RD148B2C101J	RES. CARBON 100 5% 1/6W
R066	RD148B2C362J	RES. CARBON 3.6K 5% 1/6W
R067	RD148B2C911J	RES. CARBON 910 5% 1/6W
R068	RD148B2C101J	RES. CARBON 100 5% 1/6W
R069	RD148B2C101J	RES. CARBON 100 5% 1/6W
R070	NO USE	
R071	RD148B2C105J	RES. CARBON 1M 5% 1/6W
R072	RD148B2E330J	RES. CARBON 33 5% 1/4W
R073	RD14CB2C684J	RES. CARBON 680K 5% 1/6W
R074	RD148B2C220J	RES. CARBON 22 5% 1/6W
R075	RN148K2C5003F	RES. METAL FILM 500K 1% 1/6W
R076	RN148K2E5003F	RES. METAL FILM 500K 1% 1/4W
R077	RD148B2C684J	RES. CARBON 680K 5% 1/6W
R078	RD148B2E105J	RES. CARBON 1M 5% 1/4W
R079	RD148B2E162J	RES. CARBON 1.6K 5% 1/4W
R080	RD148B2C100J	RES. CARBON 10 5% 1/6W
R081	RD148B2C103J	RES. CARBON 10K 5% 1/6W
R082	RD148B2E132J	RES. CARBON 1.3K 5% 1/4W
R083	RD148B2C101J	RES. CARBON 100 5% 1/6W
R084	RD148B2C101J	RES. CARBON 100 5% 1/6W
R085	RD148B2C100J	RES. CARBON 10 5% 1/6W
R086	RD148B2C331J	RES. CARBON 330 5% 1/6W
R087	RD148B2C101J	RES. CARBON 100 5% 1/6W
R088	RD148B2C751J	RES. CARBON 750 5% 1/6W
R089	RD148B2C181J	RES. CARBON 180 5% 1/6W
R090	RN148K2C30ROF	RES. METAL FILM 30.0 1% 1/6W
R091	NO USE	
R092	RD148B2C621J	RES. CARBON 620 5% 1/6W
R093	RD148B2C270J	RES. CARBON 27 5% 1/6W
R094	R92-1162-05	RES. METAL FILM 560 5% 1/8W
R095	RN148K2E1800F	RES. METAL FILM 180 1% 1/4W
R096	RD148B2C271J	RES. CARBON 270 5% 1/6W
R097	NO USE	
R098	RD148B2C470J	RES. CARBON 47 5% 1/6W
R099	RD148B2C560J	RES. CARBON 56 5% 1/6W
R100	RD148B2E104J	RES. CARBON 100K 5% 1/4W
R101	RN148K2E1801F	RES. METAL FILM 1.8K 1% 1/4W
R102	RN148K2E1801F	RES. METAL FILM 1.8K 1% 1/4W
R103	RN148K2C2700F	RES. METAL FILM 270 1% 1/6W
R104	RN148K2C12ROF	RES. METAL FILM 12.0 1% 1/6W
R105	RN148K2E1601F	RES. METAL FILM 1.6K 1% 1/4W
R106	RN148K2E1601F	RES. METAL FILM 1.6K 1% 1/4W
R107	RN148K2E3900F	RES. METAL FILM 390 1% 1/4W
R108	RD148B2E101J	RES. CARBON 100 5% 1/4W
R109	RD148B2E101J	RES. CARBON 100 5% 1/4W
R110	RN148K2E6800F	RES. METAL FILM 680 1% 1/4W
R111	RN148K2E6800F	RES. METAL FILM 680 1% 1/4W
R112	RN148K2E5101F	RES. METAL FILM 5.1K 1% 1/4W
R113	RN148K2E4700F	RES. METAL FILM 470 1% 1/4W
R114	RN148K2E3001F	RES. METAL FILM 3K 1% 1/4W
R115	RN148K2E7500F	
R116	RN148K2E7500F	
R117	RD148B2C220J	RES. CARBON 22 5% 1/6W
R118	RD148B2C220J	RES. CARBON 22 5% 1/6W
R119	RN148K2E1002F	RES. METAL FILM 10K 1% 1/4W
R120	RN148K2E3001F	RES. METAL FILM 3K 1% 1/4W
R121	RN148K2E1002F	RES. METAL FILM 10K 1% 1/4W
R122	RN148K2E3001F	RES. METAL FILM 3K 1% 1/4W
R123	RD148B2E101J	RES. CARBON 100 5% 1/4W
R124	RD148B2E101J	RES. CARBON 100 5% 1/4W
R125	RD148B2E101J	RES. CARBON 100 5% 1/4W
R126	RD148B2E101J	RES. CARBON 100 5% 1/4W
R127	RD148B2E432J	RES. CARBON 4.3K 5% 1/4W
R128	RN148K2C9100F	RES. METAL FILM 910 1% 1/6W
R129	RN148K2C9100F	RES. METAL FILM 910 1% 1/6W
R130	RN148K2E8200F	RES. METAL FILM 820 1% 1/4W
R131	RN148K2C8200F	RES. METAL FILM 820 1% 1/6W
R132	RD148B2E470J	RES. CARBON 47 5% 1/4W
R133	RD148B2E470J	RES. CARBON 47 5% 1/4W
R134	RN148K2E6800F	RES. METAL FILM 680 1% 1/4W

# PARTS LIST

REF.NO	PARTS NO	NAME & DESCRIPTION	REF.NO	PARTS NO	NAME & DESCRIPTION
R135	RN14BK2E6800F	RES. METAL FILM 680 1% 1/4W	R223	RN14BK2C51ROF	RES. METAL FILM 51.0 1% 1/6W
R136	RN14BK2E8200F	RES. METAL FILM 820 1% 1/4W	R224	RN14BK2C51ROF	RES. METAL FILM 51.0 1% 1/6W
R137	RD14BB2C101J	RES. CARBON 100 5% 1/6W	R225	RN14BK2C1000F	RES. METAL FILM 100 1% 1/6W
R138	RD14BB2E101J	RES. CARBON 100 5% 1/4W	R226	RN14BK2E1000F	
R139	RD14BB2E272J	RES. CARBON 2.7K 5% 1/4W	R227	RN14BK2E1000F	
R140	RD14BB2E272J	RES. CARBON 2.7K 5% 1/4W	R228	RD14BB2C220J	RES. CARBON 22 5% 1/6W
R141	RD14BB2C362J	RES. CARBON 3.6K 5% 1/6W	R229	RD14BB2E682J	RES. CARBON 6.8K 5% 1/4W
R142	RD14BB2C911J	RES. CARBON 910 5% 1/6W	R230	RD14BB2C103J	RES. CARBON 10K 5% 1/6W
R143	RD14BB2C101J	RES. CARBON 100 5% 1/6W	R231	RD14BB2C472J	RES. CARBON 4.7K 5% 1/6W
R144	RD14BB2C101J	RES. CARBON 100 5% 1/6W	R232	RD14BB2E472J	RES. CARBON 4.7K 5% 1/4W
R145	RD14BB2C183J	RES. CARBON 18K 5% 1/6W	R233	RD14BB2E220J	RES. CARBON 22 5% 1/4W
R146	RN14BK2E9003F		R234	RD14BB2E220J	RES. CARBON 22 5% 1/4W
R147	RN14BK2E1003F	RES. METAL FILM 100K 1% 1/4W	R235	RD14BB2E682J	RES. CARBON 6.8K 5% 1/4W
R148	RD14BB2E684J	RES. CARBON 680K 5% 1/4W	R236	RN14BK2E1000F	
R149	RD14BB2C101J	RES. CARBON 100 5% 1/6W	R237	RN14BK2E1000F	
R150	RD14BB2C684J	RES. CARBON 680K 5% 1/6W	R238	RN14BK2E1000F	
R151	RD14BB2C101J	RES. CARBON 100 5% 1/6W	R239	RD14BB2E511J	RES. CARBON 510 5% 1/4W
R152	RD14BB2E122J	RES. CARBON 1.2K 5% 1/4W	R240	RD14BB2E682J	RES. CARBON 6.8K 5% 1/4W
R153	RD14BB2E102J	RES. CARBON 1K 5% 1/4W	R241	RD14BB2E332J	RES. CARBON 3.3K 5% 1/4W
R154	RD14BB2E101J	RES. CARBON 100 5% 1/4W	R242	RD14BB2E331J	RES. CARBON 330 5% 1/4W
R155	RD14BB2E162J	RES. CARBON 1.6K 5% 1/4W	R243	RD14BB2C202J	RES. CARBON 2K 5% 1/6W
R156	RD14BB2C432J	RES. CARBON 4.3K 5% 1/6W	R244	RD14BB2C202J	RES. CARBON 2K 5% 1/6W
R157	RD14BB2E101J	RES. CARBON 100 5% 1/4W	R245	RD14BB2C681J	RES. CARBON 680 5% 1/6W
R158	RN14BK2E7500F		R246	RD14BB2C101J	RES. CARBON 100 5% 1/6W
R159	RN14BK2E7500F		R247	RD14BB2C512J	RES. CARBON 5.1K 5% 1/6W
R160	R92-1162-05	RES. METAL FILM 560 5% 1/8W	R248	RD14BB2C242J	RES. CARBON 2.4K 5% 1/6W
R161	RD14BB2C101J	RES. CARBON 100 5% 1/6W	R249	RD14BB2C302J	RES. CARBON 3K 5% 1/4W
R162	RD14BB2E101J	RES. CARBON 100 5% 1/4W	R250	RD14BB2C621J	RES. CARBON 620 5% 1/6W
R163	RD14BB2E272J	RES. CARBON 2.7K 5% 1/4W	R251	RD14BB2E622J	RES. CARBON 6.2K 5% 1/4W
R164	RD14BB2C272J	RES. CARBON 2.7K 5% 1/6W	R252	RN14BK2E2490F	
R165	RD14BB2C362J	RES. CARBON 3.6K 5% 1/6W	R253	RD14BB2C272J	RES. CARBON 2.7K 5% 1/6W
R166	RD14BB2C911J	RES. CARBON 910 5% 1/6W	R254	RD14BB2C272J	RES. CARBON 2.7K 5% 1/6W
R167	RD14BB2C101J	RES. CARBON 100 5% 1/6W	R255	RD14BB2C561J	RES. CARBON 560 5% 1/6W
R168	RD14BB2C101J	RES. CARBON 100 5% 1/6W	R256	RD14BB2C561J	RES. CARBON 560 5% 1/6W
R169	RN14BK2C7500F	RES. METAL FILM 750 1% 1/6W	R257	RD14BB2C511J	RES. CARBON 510 5% 1/6W
R170	RN14BK2C7500F	RES. METAL FILM 750 1% 1/6W	R258	RD14BB2C751J	RES. CARBON 750 5% 1/6W
R171	RN14BK2C6980F	RES. METAL FILM 698 1% 1/6W	R259	RD14BB2C751J	RES. CARBON 750 5% 1/6W
R172	RN14BK2C6980F	RES. METAL FILM 698 1% 1/6W	R260	RD14BB2C470J	RES. CARBON 47 5% 1/6W
R173	RD14BB2E470J	RES. CARBON 47 5% 1/4W	R261	RD14BB2C471J	RES. CARBON 470 5% 1/6W
R174	RD14BB2E470J	RES. CARBON 47 5% 1/4W	R262	RD14BB2C471J	RES. CARBON 470 5% 1/6W
R175	RD14BB2C100J	RES. CARBON 10 5% 1/6W	R263	RD14BB2C471J	RES. CARBON 470 5% 1/6W
R176	NO USE		R264	RD14BB2E472J	RES. CARBON 4.7K 5% 1/4W
R177	RD14BB2C302J	RES. CARBON 3K 5% 1/6W	R265	RD14BB2C472J	RES. CARBON 4.7K 5% 1/6W
R178	RD14BB2C302J	RES. CARBON 3K 5% 1/6W	R266	RD14BB2C472J	RES. CARBON 4.7K 5% 1/6W
R179	RD14BB2C101J	RES. CARBON 100 5% 1/6W	R267	RD14BB2E471J	RES. CARBON 470 5% 1/4W
R180	RD14BB2C101J	RES. CARBON 100 5% 1/6W	R268	RD14BB2C104J	RES. CARBON 100K 5% 1/6W
R181	RD14BB2E220J	RES. CARBON 22 5% 1/4W	R269	NO USE	
R182	RD14BB2C220J	RES. CARBON 22 5% 1/6W	R270	RD14BB2C103J	RES. CARBON 10K 5% 1/6W
R183	RN14BK2E8200F	RES. METAL FILM 820 1% 1/4W	R271	RD14BB2E103J	RES. CARBON 10K 5% 1/4W
R184	RN14BK2C8200F	RES. METAL FILM 820 1% 1/6W	R272	RD14BB2E103J	RES. CARBON 10K 5% 1/4W
R185	RN14BK2E7500F		R273	RD14BB2E103J	RES. CARBON 10K 5% 1/4W
R186	RN14BK2E2201F	RES. METAL FILM 2.2K 1% 1/4W	R274	RD14BB2C101J	RES. CARBON 100 5% 1/6W
R187	RN14BK2E2201F	RES. METAL FILM 2.2K 1% 1/4W	R275	RD14BB2C101J	RES. CARBON 100 5% 1/6W
R188	RN14BK2C8200F	RES. METAL FILM 820 1% 1/6W	R276	RD14BB2C161J	RES. CARBON 160 5% 1/6W
R189	RN14BK2E8200F	RES. METAL FILM 820 1% 1/4W	R279	RD14BB2C301J	RES. CARBON 300 5% 1/6W
R190	RD14BB2C220J	RES. CARBON 22 5% 1/6W	R280	RD14BB2C101J	RES. CARBON 100 5% 1/6W
R191	RD14BB2E220J	RES. CARBON 22 5% 1/4W	R281	RD14BB2C101J	RES. CARBON 100 5% 1/6W
R192	RN14BK2C6200F	RES. METAL FILM 620 1% 1/6W	R282	RD14BB2C301J	RES. CARBON 300 5% 1/6W
R193	RN14BK2C6200F	RES. METAL FILM 620 1% 1/6W	R283	RD14BB2C100J	RES. CARBON 10 5% 1/6W
R194	RD14BB2C430J	RES. CARBON 43 5% 1/6W	R284	NO USE	
R195	RD14BB2C222J	RES. CARBON 2.2K 5% 1/6W	R285	RD14BB2C331J	RES. CARBON 330 5% 1/6W
R196	RD14BB2C332J	RES. CARBON 3.3K 5% 1/6W	R286	RD14BB2C102J	RES. CARBON 1K 5% 1/6W
R197	RD14BB2E332J	RES. CARBON 3.3K 5% 1/4W	R287	RD14BB2C102J	RES. CARBON 1K 5% 1/6W
R198	RN14BK2C5600F	RES. METAL FILM 560 1% 1/6W	R288	RD14BB2C102J	RES. CARBON 1K 5% 1/6W
R199	RN14BK2C1800F	RES. METAL FILM 180 1% 1/6W	R289	RD14BB2E100J	RES. CARBON 10 5% 1/4W
R200	RD14BB2C101J	RES. CARBON 100 5% 1/6W	R290	RD14BB2C470J	RES. CARBON 47 5% 1/6W
R201	RD14BB2C101J	RES. CARBON 100 5% 1/6W	R291	RD14BB2C470J	RES. CARBON 47 5% 1/6W
R202	RD14BB2E302J	RES. CARBON 3K 5% 1/4W	R292	RD14BB2C470J	RES. CARBON 47 5% 1/6W
R203	RD14BB2E302J	RES. CARBON 3K 5% 1/4W	R293	RD14BB2E470J	RES. CARBON 47 5% 1/4W
R204	RD14BB2E101J	RES. CARBON 100 5% 1/4W	R294	RD14BB2E101J	RES. CARBON 100 5% 1/4W
R205	RD14BB2E101J	RES. CARBON 100 5% 1/4W	R295	RD14BB2E101J	RES. CARBON 100 5% 1/4W
R206	RN14BK2C51ROF	RES. METAL FILM 51.0 1% 1/6W	R296	RD14BB2C332J	RES. CARBON 3.3K 5% 1/6W
R207	RN14BK2C51ROF	RES. METAL FILM 51.0 1% 1/6W	R297	RD14BB2E101J	RES. CARBON 100 5% 1/4W
R208	RD14BB2C101J	RES. CARBON 100 5% 1/6W	R298	RD14BB2E101J	RES. CARBON 100 5% 1/4W
R209	RD14BB2C101J	RES. CARBON 100 5% 1/6W	R299	RD14BB2C332J	RES. CARBON 3.3K 5% 1/6W
R210	RD14BB2E302J	RES. CARBON 3K 5% 1/4W	R300	NO USE	
R211	RD14BB2E302J	RES. CARBON 3K 5% 1/4W	R301	RD14BB2C333J	RES. CARBON 33K 5% 1/6W
R212	RD14BB2E101J	RES. CARBON 100 5% 1/4W	R302	RD14BB2C101J	RES. CARBON 100 5% 1/6W
R213	RD14BB2E101J	RES. CARBON 100 5% 1/4W	R303	RD14BB2E101J	RES. CARBON 100 5% 1/4W
R214	RN14BK2E51ROF		R304	RD14BB2C332J	RES. CARBON 3.3K 5% 1/6W
R215	RN14BK2E51ROF		R305	RD14BB2C101J	RES. CARBON 100 5% 1/6W
R216	RD14BB2C132J	RES. CARBON 1.3K 5% 1/6W	R306	RD14BB2E101J	RES. CARBON 100 5% 1/4W
R217	RD14BB2C101J	RES. CARBON 100 5% 1/6W	R307	RD14BB2C332J	RES. CARBON 3.3K 5% 1/6W
R218	RD14BB2E101J	RES. CARBON 100 5% 1/4W	R308	NO USE	
R219	RD14BB2E302J	RES. CARBON 3K 5% 1/4W	R309	RD14BB2C333J	RES. CARBON 33K 5% 1/6W
R220	RD14BB2E302J	RES. CARBON 3K 5% 1/4W	R310	RD14BB2C912J	RES. CARBON 9.1K 5% 1/6W
R221	RD14BB2E101J	RES. CARBON 100 5% 1/4W	R311	RD14BB2C822J	RES. CARBON 8.2K 5% 1/6W
R222	RD14BB2E101J	RES. CARBON 100 5% 1/4W			

# PARTS LIST

REF. NO	PARTS NO	NAME & DESCRIPTION
R312	RD14BB2C332J	RES. CARBON 3.3K 5% 1/6W
R313	RD14BB2C101J	RES. CARBON 100 5% 1/6W
R314	RD14BB2E101J	RES. CARBON 100 5% 1/4W
R315	RD14BB2E101J	RES. CARBON 100 5% 1/4W
R316	RD14BB2C331J	RES. CARBON 330 5% 1/6W
R317	RD14BB2C331J	RES. CARBON 330 5% 1/6W
R318	RD14BB2C152J	RES. CARBON 1.5K 5% 1/6W
R319	NO USE	
R320	RD14BB2C161J	RES. CARBON 160 5% 1/6W
R321	RD14BB2C161J	RES. CARBON 160 5% 1/6W
R322	RD14BB2C270J	RES. CARBON 27 5% 1/6W
R323	RD14BB2C331J	RES. CARBON 330 5% 1/6W
S001	S32-4007-05	LEVER SWITCH 4-3
S002	S32-4007-05	LEVER SWITCH 4-3
S003	S33-2501-05	LEVER SWITCH 2-5
TC002	C05-0444-05	CAP. TRIMMER 10P
TC003	NO USE	
TC004	C05-0444-05	CAP. TRIMMER 10P
TC005	C05-0444-05	CAP. TRIMMER 10P
TC006	C05-0444-05	CAP. TRIMMER 10P
TC007	C05-0444-05	CAP. TRIMMER 10P
TC008	C05-0444-05	CAP. TRIMMER 10P
TC009	C05-0444-05	CAP. TRIMMER 10P
TH001	SDT1000	THERMISTOR
TH002	SDT100	THERMISTOR
TH003	SDT100	THERMISTOR
TH004	SDT100	THERMISTOR
U001	LF411CN	IC,DUAL JFET INPUT OP AMP
U002	CA3127E	IC. TR. ARRY N-P-N
U003	LF411CN	IC,DUAL JFET INPUT OP AMP
U004	CA3127E	IC. TR. ARRY N-P-N
VR001	R12-4510-05	RES. SEMI FIXED 50K B
VR002	R12-0563-05	RES. SEMI FIXED 500B
VR003	R12-0561-05	RES. SEMI FIXED 100 B
VR004	R12-4510-05	RES. SEMI FIXED 50K B
VR007	R12-0561-05	RES. SEMI FIXED 100 B
VR008	R12-1528-05	RES. SEMI FIXED 1K B
VR009	R01-1513-05	V.R. 2K B
VR010	R12-4510-05	RES. SEMI FIXED 50K B
VR011	R12-0563-05	RES. SEMI FIXED 500B
VR012	R12-0561-05	RES. SEMI FIXED 100 B
VR013	R12-4510-05	RES. SEMI FIXED 50K B
VR016	R12-0561-05	RES. SEMI FIXED 100 B
VR017	R12-0561-05	RES. SEMI FIXED 100 B
VR018	R12-1528-05	RES. SEMI FIXED 1K B
VR019	R12-1037-05	RES. SEMI FIXED 3.3K B
VR020	R12-0563-05	RES. SEMI FIXED 500B
VR021	R12-2517-05	RES. SEMI FIXED 5K B
VR022	R12-0561-05	RES. SEMI FIXED 100 B
VR023	R12-0561-05	RES. SEMI FIXED 100 B
VR024	R12-0561-05	RES. SEMI FIXED 100 B
VR025	NO USE	
VR026	R12-0561-05	RES. SEMI FIXED 100 B
VR027	R12-2517-05	RES. SEMI FIXED 5K B
VR028	R01-1513-05	V.R. 2K B
VR029	R06-1503-05	V.R. 2K B X2
VR030	R12-0561-05	RES. SEMI FIXED 100 B
VR031	R12-0561-05	RES. SEMI FIXED 100 B

REF. NO	PARTS NO	NAME & DESCRIPTION
C006	C092FM1H103K	CAP. MYLAR 0.01 10% 50V
C007	C092FM1H102K	CAP. MYLAR 1000P 10% 50V
C008	NO USE	
C009	CK45B2H103K	CAP. CERAMIC 0.01 10% 500V
C010	CC45CH1H120J	CAP. CERAMIC 12P 5% 50V
C011	C91-1233-05	CAP. CERAMIC 6.8P 10% 3KV
C012	CE04EW1H010M	CAP. ELECTRO 1 20% 50V
C013	C91-0769-05	CAP. AXIAL 0.01 20% 16V
C014	CE04EW2A4R7M	CAP. ELECTRO 4.7 20% 100V
C015	CE04EW1A470M	CAP. ELECTRO 47 20% 10V
C016	CE04BW1E220M	CAP. ELECTRO 22 20% 25V
C017	CE04W2C010M	CAP. ELECTRO 1 20% 160V
C018	CE04EW2A471M	CAP. ELECTRO 470 20% 100V
C019	CE04W2E470M	CAP. ELECTRO 47 20% 250V
C020	CE04EW1C472M	CAP. ELECTRO 4700 20% 16V
C021	CE04EW1E220M	CAP. ELECTRO 22 20% 25V
C022	CE04EW1E220M	CAP. ELECTRO 22 20% 25V
C023	CE04EW1C330M	CAP. ELECTRO 33 20% 16V
C024	CE04EW1E332M	CAP. ELECTRO 3300 20% 25V
C025	CE04EW1E332M	CAP. ELECTRO 3300 20% 25V
C026	CE04EW1C330M	CAP. ELECTRO 33 20% 16V
C027	CE04EW1E220M	CAP. ELECTRO 22 20% 25V
C028	CE04EW1E220M	CAP. ELECTRO 22 20% 25V
C029	C092FM1H103K	CAP. MYLAR 0.01 10% 50V
C030	CC45CH1H330J	CAP. CERAMIC 33P 5% 50V
C031	C092M1H103K	CAP. MYLAR 0.01 10% 50V
C032	C092M1H103K	CAP. MYLAR 0.01 10% 50V
C033	CE04EW1H010M	CAP. ELECTRO 1 20% 50V
C034	CE04EW1H010M	CAP. ELECTRO 1 20% 50V
C035	C91-0757-05	CAP. CERAMIC 1000P 10% 50V
C036	C91-0757-05	CAP. CERAMIC 1000P 10% 50V

D001	1SS132	DIODE
D002	1SS132	DIODE
D003	S1VB40	DIODE, BRIDGE
D004	S2VB40F1	DIODE, BRIDGE
D005	S4VB40F1	DIODE, BRIDGE
D006	S1VB40	DIODE, BRIDGE
D007	1SS132	DIODE
D008	1SS132	DIODE
D009	NO USE	
D010	MTZ7.5JA	DIODE, ZENER 7.1V
D011	MTZ11JC	DIODE, ZENER 11V
D012	MTZ11JC	DIODE, ZENER 11V
D013	MTZ3.3JA	DIODE, ZENER 3.2V
D014	MTZ3.3JA	DIODE, ZENER 3.2V
D015	MTZ8.2JA	DIODE, ZENER 9.6V

L001	L40-1011-04	FERRI INDUCTOR 100UH (7H)
L002	L40-1011-04	FERRI INDUCTOR 100UH (7H)

L005	L33-0806-05	CHOKO COIL (0.52UH)
L006	L33-0806-05	CHOKO COIL (0.52UH)

P009	E40-0673-05	PIN CONNECTOR 6P
P012	E40-0473-05	PIN CONNECTOR 4P
P013	NO USE	
P014	E40-0373-05	PIN CONNECTOR 3P

P019	E40-0273-05	PIN CONNECTOR 2P
P020	NO USE	
P021	E40-0373-05	PIN CONNECTOR 3P

P032	E40-0873-05	PIN CONNECTOR 8P
P036	E40-1004-05	PIN CONNECTOR 10P

P040	E40-0273-05	PIN CONNECTOR 2P
P041	E40-0273-05	PIN CONNECTOR 2P
P042	E40-0311-05	PIN CONNECTOR 3P

P054	E40-0273-05	PIN CONNECTOR 2P
------	-------------	------------------

Q001	2SA1206	TR. SI, PNP
Q002	2SA1206	TR. SI, PNP
Q003	2SC2644	TR. SI, NPN
Q004	2SC2644	TR. SI, NPN
Q005	2SC2644	TR. SI, NPN
Q006	2SC2644	TR. SI, NPN
Q007	2SC2644	TR. SI, NPN
Q008	2SC2644	TR. SI, NPN
Q009	2SC2644	TR. SI, NPN
Q010	2SC2644	TR. SI, NPN
Q011	2SC2644	TR. SI, NPN
Q012	2SC2644	TR. SI, NPN
Q013	2SC1164(D)	TR. SI, NPN
Q014	2SC1164(D)	TR. SI, NPN

## POWER & FINAL AMP UNIT

### X73-1660-00

REF. NO	PARTS NO	NAME & DESCRIPTION
E31	E31-2613-05	WIRE ASS'Y (J50, 51)
F01	F01-0855-03	HEAT SINK
F02	F02-0511-05	HEAT SINK (Q13, 14)
J12	J12-0504-05	SPRING PIPE
J25	J25-5105-23	PCB (UNMOUNTED)
J30	J30-0605-05	SPACER
N09	N09-0623-04	SCREW, SEMS M3X8
N09	N09-0731-05	SCREW M3X12
N14	N14-0626-04	NUT
R92	R92-0150-05	JUMPING RES. ZERO OHM(10MM)
C001	CE04EW1C330M	CAP. ELECTRO 33 20% 16V
C002	CE04EW1C330M	CAP. ELECTRO 33 20% 16V
C003	CE04EW1C330M	CAP. ELECTRO 33 20% 16V
C004	CC45SL1H471J	CAP. CERAMIC 470P 5% 50V
C005	NO USE	

# PARTS LIST

REF. NO	PARTS NO	NAME & DESCRIPTION			
Q015	2SC2271(D)	TR. SI. NPN			
Q016	2SD1263A(P,Q,R)	TR. SI. NPN			
Q017	2SC2271(D)	TR. SI. NPN			
Q018	2SD1263A(P,Q,R)	TR. SI. NPN			
Q019	2SB943(P,Q,R)	TR. SI. PNP			
Q020	2SC2785(F)	TR. SI. NPN			
Q021	2SD1268(P,Q,R)	TR. SI. NPN			
Q022	2SB943(P,Q,R)	TR. SI. PNP			
Q023	2SA684(Q,R,S)	TR. SI. PNP			
Q024	2SD1268(P,Q,R)	TR. SI. NPN			
Q025	2SC1384(Q,R,S)	TR. SI. NPN			
Q026	2SD1262A(Q)	TR. SI. NPN			
Q027	2SB939A(Q)	TR. SI. PNP			
R001	RN14BK2C91ROF	RES. METAL FILM 91.0	1%	1/6W	
R002	RN14BK2C91ROF	RES. METAL FILM 91.0	1%	1/6W	
R003	RD14BB2C561J	RES. CARBON 560	5%	1/6W	
R004	RD14BB2C561J	RES. CARBON 560	5%	1/6W	
R005	RD14BB2C101J	RES. CARBON 100	5%	1/6W	
R006	RD14BB2C101J	RES. CARBON 100	5%	1/6W	
R007	RN14BK2C3900F	RES. METAL FILM 390	1%	1/6W	
R008	RN14BK2C3900F	RES. METAL FILM 390	1%	1/6W	
R009	RN14BK2C2401F	RES. METAL FILM 2.4K	1%	1/6W	
R010	RN14BK2C2401F	RES. METAL FILM 2.4K	1%	1/6W	
R011	RD14BB2C101J	RES. CARBON 100	5%	1/6W	
R012	RD14BB2C101J	RES. CARBON 100	5%	1/6W	
R013	RN14BK2C3600F	RES. METAL FILM 360	1%	1/6W	
R014	RN14BK2C3600F	RES. METAL FILM 360	1%	1/6W	
R015	RN14BK2C2200F	RES. METAL FILM 220	1%	1/6W	
R016	RD14BB2C133J	RES. CARBON 13K	5%	1/6W	
R017	RD14BB2E220J	RES. CARBON 22	5%	1/4W	
R018	RD14BB2E220J	RES. CARBON 22	5%	1/4W	
R019	RD14BB2C100J	RES. CARBON 10	5%	1/6W	
R020	RD14BB2C100J	RES. CARBON 10	5%	1/6W	
R021	RN14BK2C4300F	RES. METAL FILM 430	1%	1/6W	
R022	RN14BK2C4300F	RES. METAL FILM 430	1%	1/6W	
R025	RD14BB2C391J	RES. CARBON 390	5%	1/6W	
R026	RD14BB2C391J	RES. CARBON 390	5%	1/6W	
R027	RD14BB2C470J	RES. CARBON 47	5%	1/6W	
R028	RD14BB2C470J	RES. CARBON 47	5%	1/6W	
R029	RD14BB2C470J	RES. CARBON 47	5%	1/6W	
R030	RD14BB2C470J	RES. CARBON 47	5%	1/6W	
R031	RD14BB2C303J	RES. CARBON 30K	5%	1/6W	
R032	RN14BK2C3901F	RES. METAL FILM 3.9K	1%	1/6W	
R033	RN14BK2E1100F	RES. METAL FILM 110	1%	1/4W	
R034	RN14BK2E1100F	RES. METAL FILM 110	1%	1/4W	
R035	RD14BB2C392J	RES. CARBON 3.9K	5%	1/6W	
R036	RD14BB2C100J	RES. CARBON 10	5%	1/6W	
R037	RD14BB2C100J	RES. CARBON 10	5%	1/6W	
R038	RD14BB2C470J	RES. CARBON 47	5%	1/6W	
R039	RD14BB2C470J	RES. CARBON 47	5%	1/6W	
R040	RN14BK2C6802F	RES. METAL FILM 68K	1%	1/6W	
R041	RN14BK2C6802F	RES. METAL FILM 68K	1%	1/6W	
R042	NO USE				
R043	RN14BK2E1100F	RES. METAL FILM 110	1%	1/4W	
R044	RS14AB3Y391J	RES. METAL FILM 390	5%	7W	
R045	RS14AB3Y391J	RES. METAL FILM 390	5%	7W	
R046	RN14BK2E1100F	RES. METAL FILM 110	1%	1/4W	
R047	NO USE				
R048	RD14BB2C102J	RES. CARBON 1K	5%	1/6W	
R049	RD14BB2C103J	RES. CARBON 10K	5%	1/6W	
R050	RN14BK2C9101F	RES. METAL FILM 9.1K	1%	1/6W	
R051	RD14BB2C301J	RES. CARBON 300	5%	1/6W	
R052	RD14BB2C102J	RES. CARBON 1K	5%	1/6W	
R053	RD14BB2C102J	RES. CARBON 1K	5%	1/6W	
R054	RD14BB2C163J	RES. CARBON 16K	5%	1/6W	
R055	RN14BK2C2002F	RES. METAL FILM 20K	1%	1/6W	
R056	RN14BK2C1203F	RES. METAL FILM 120K	1%	1/6W	
R057	RD14BB2C102J	RES. CARBON 1K	5%	1/6W	
R058	RD14BB2C102J	RES. CARBON 1K	5%	1/6W	
R059	RD14BB2C183J	RES. CARBON 18K	5%	1/6W	
R060	RN14BK2C2002F	RES. METAL FILM 20K	1%	1/6W	
R061	RN14BK2E2403F	RES. METAL FILM 240K	1%	1/4W	
R062	RD14BB2C102J	RES. CARBON 1K	5%	1/6W	
R063	RD14BB2C103J	RES. CARBON 10K	5%	1/6W	
R064	RN14BK2C9100F	RES. METAL FILM 910	1%	1/6W	
R065	RD14BB2C221J	RES. CARBON 220	5%	1/6W	
R066	RD14BB2C682J	RES. CARBON 6.8K	5%	1/6W	
R067	RN14BK2C2002F	RES. METAL FILM 20K	1%	1/6W	
R068	RN14BK2C1002F	RES. METAL FILM 10K	1%	1/6W	
R069	RD14BB2C102J	RES. CARBON 1K	5%	1/6W	
R070	RD14BB2C473J	RES. CARBON 47K	5%	1/6W	
R071	RS14GB3A273J	RES. METAL FILM 27K	5%	1W	
R072	RD14BB2C105J	RES. CARBON 1M	5%	1/6W	
R073	RD14BB2E103J	RES. CARBON 10K	5%	1/4W	
R074	RS14GB3A163J	RES. METAL FILM 16K	5%	1W	
R075	RD14BB2C105J	RES. CARBON 1M	5%	1/6W	

REF. NO	PARTS NO	NAME & DESCRIPTION			
R076	RD14BB2C302J	RES. CARBON 3K	5%	1/6W	
R077	NO USE				
R078	RD14BB2C241J	RES. CARBON 240	5%	1/6W	
R079	RN14BK2C3301F	RES. METAL FILM 3.3K	1%	1/6W	
R080	RN14BK2C9101F	RES. METAL FILM 9.1K	1%	1/6W	
R081	RN14BK2C2002F	RES. METAL FILM 20K	1%	1/6W	
R082	RN14BK2C2002F	RES. METAL FILM 20K	1%	1/6W	
R083	RD14BB2C102J	RES. CARBON 1K	5%	1/6W	
R084	RD14BB2C473J	RES. CARBON 47K	5%	1/6W	
R085	RN14BK2C4302F	RES. METAL FILM 43K	1%	1/6W	
R086	RN14BK2C1003F	RES. METAL FILM 100K	1%	1/6W	
R087	RN14BK2C9102F	RES. METAL FILM 91K	1%	1/6W	
R088	RD14BB2C104J	RES. CARBON 100K	5%	1/6W	
R089	RN14BK2C8200F	RES. METAL FILM 820	1%	1/6W	
R090	RN14BK2C1000F	RES. METAL FILM 100	1%	1/6W	
R091	RD14BB2C101J	RES. CARBON 100	5%	1/6W	
R092	RD14BB2C180J	RES. CARBON 18	5%	1/6W	
R093	NO USE				
R094	RD14BB2C101J	RES. CARBON 100	5%	1/6W	
R095	RD14BB2C221J	RES. CARBON 220	5%	1/6W	
R096	RD14BB2C221J	RES. CARBON 220	5%	1/6W	
R097	RD14BB2E220J	RES. CARBON 22	5%	1/4W	
R098	RD14BB2E220J	RES. CARBON 22	5%	1/4W	
R099	RD14BB2C561J	RES. CARBON 560	5%	1/6W	
R100	RD14BB2C243J	RES. CARBON 24K	5%	1/6W	
R101	NO USE				
R102	RD14BB2C102J	RES. CARBON 1K	5%	1/6W	
R103	RD14BB2C102J	RES. CARBON 1K	5%	1/6W	
R106	RD14BB2C101J	RES. CARBON 100	5%	1/6W	
R107	RD14BB2C101J	RES. CARBON 100	5%	1/6W	
R108	RD14BB2C181J	RES. CARBON 180	5%	1/6W	
R109	RD14BB2E471J	RES. CARBON 470	5%	1/4W	
R110	RD14BB2E471J	RES. CARBON 470	5%	1/4W	
TC001	C05-0444-05	CAP. TRIMMER	10P		
TC002	C05-0444-05	CAP. TRIMMER	10P		
U001	NJM4558D	IC. OP AMP			
U002	NJM4558D	IC. OP AMP			
U003	NJM4558D	IC. OP AMP			
U004	NJM4558D	IC. OP AMP			
VR001	R12-1529-05	RES. SEMI FIXED 2K B			
VR002	R12-0561-05	RES. SEMI FIXED 100 B			
VR003	R12-0561-05	RES. SEMI FIXED 100 B			

## SWEEP UNIT

### X74-1440-02

REF. NO	PARTS NO	NAME & DESCRIPTION			
	F01-0820-04	HEAT SINK			
	J25-5103-22	PCB (UNMOUNTED)			
	J61-0408-05	WIRE WRAPPING BAND			
	N30-3006-41	SCREW, PAN HD	M3X6		
	R92-0150-05	JUMPING RES.	ZERO OHM (10MM)		
	R92-1061-05	JUMPING RES.	ZERO OHM (5MM)		
C001	C092FM1H473K	CAP. MYLAR	0.047	10%	50V
C002	C91-0769-05	CAP. AXIAL	0.01	20%	16V
C003	C91-0769-05	CAP. AXIAL	0.01	20%	16V
C004	CC45CH1H101J	CAP. CERAMIC	100P	5%	50V
C005	C91-0769-05	CAP. AXIAL	0.01	20%	16V
C006	CE04EW1C470M	CAP. ELECTRO	47	20%	16V
C007	CE04EW1C470M	CAP. ELECTRO	47	20%	16V
C008	C092FM1H104K	CAP. MYLAR	0.1	10%	50V
C009	C092FM1H104K	CAP. MYLAR	0.1	10%	50V
C010	C91-0769-05	CAP. AXIAL	0.01	20%	16V
C011	C91-0769-05	CAP. AXIAL	0.01	20%	16V
C012	C91-0769-05	CAP. AXIAL	0.01	20%	16V
C013	CC45CH1H680J	CAP. CERAMIC	68P	5%	50V
C014	C91-0769-05	CAP. AXIAL	0.01	20%	16V
C015	C092FM1H104K	CAP. MYLAR	0.1	10%	50V
C016	CE04EW1C470M	CAP. ELECTRO	47	20%	16V
C017	NO USE				
C018	CC45FCH1H100D	CAP. CERAMIC	10P	0.5P	50V
C019	C092FM1H222K	CAP. MYLAR	2200P	10%	50V
C020	CC45SL1H102J	CAP. CERAMIC	1000P	5%	50V
C021	NO USE				
C022	C092FM1H104K	CAP. MYLAR	0.1	10%	50V
C023	C092FM1H102K	CAP. MYLAR	1000P	10%	50V
C024	CK45B2H472K	CAP. CERAMIC	4700P	10%	500V
C025	C91-0574-05	CAP. MYLAR	1	5%	100V
C026	C91-0573-05	CAP. MYLAR	0.01	1%	100V
C027	C092FM1H102K	CAP. MYLAR	1000P	10%	50V
C028	CM93BD2A900J	CAP. MICA	90P	5%	100V

# PARTS LIST

REF.NO	PARTS NO	NAME & DESCRIPTION			
C029	C91-0769-05	CAP. AXIAL	0.01	20%	16V
C030	CC45CH1H070D	CAP. CERAMIC	7P	0.5P	50V
C031	CE04EW1C470M	CAP. ELECTRO	47	20%	16V
C032	NO USE				
C033	C092FM1H222K	CAP. MYLAR	2200P	10%	50V
C034	NO USE				
C035	C092FM1H222K	CAP. MYLAR	2200P	10%	50V
C036	CE04EW1E4R7M	CAP. ELECTRO	4.7	20%	25V
C037	C092FM1H473K	CAP. MYLAR	0.047	10%	50V
C038	C91-0574-05	CAP. MYLAR	1	5%	100V
C039	C91-0573-05	CAP. MYLAR	0.01	1%	100V
C040	C092FM1H102K	CAP. MYLAR	1000P	10%	50V
C041	CM93BD2A900J	CAP. MICA	90P	5%	100V
C042	C092FM1H102K	CAP. MYLAR	1000P	10%	50V
C043	CC45SL1H221J	CAP. CERAMIC	220P	5%	50V
C044	CC45CH1H470J	CAP. CERAMIC	47P	5%	50V
C045	CC45CH1H470J	CAP. CERAMIC	47P	5%	50V
C046	CC45CH1H020C	CAP. CERAMIC	2P	0.25P	50V
C047	CC45CH1H020C	CAP. CERAMIC	2P	0.25P	50V
C048	NO USE				
C049	CE04EW1E330M	CAP. ELECTRO	33	20%	25V
C050	NO USE				
C051	CC45CH1H680J	CAP. CERAMIC	68P	5%	50V
C052	NO USE				
C053	CC45CH1H150J	CAP. CERAMIC	15P	5%	50V
C054	CK45B2H472K	CAP. CERAMIC	4700P	10%	500V
C055	CK45B2H472K	CAP. CERAMIC	4700P	10%	500V
C056	CE04BW1H010M	CAP. ELECTRO	1	20%	50V
C057	C90-0298-05	CAP. CERAMIC	0.1	20%	12V
C058	C90-0298-05	CAP. CERAMIC	0.1	20%	12V
C059	NO USE				
C060	CE04BW1H010M	CAP. ELECTRO	1	20%	50V
C063	CC45CH1H070D	CAP. CERAMIC	7P	0.5P	50V
C064	CC45CH1H101J	CAP. CERAMIC	100P	5%	50V
C065	CC45CH1H101J	CAP. CERAMIC	100P	5%	50V
C066	C91-0769-05	CAP. CERAMIC	0.01	20%	16V
C067	CC45CH1H030C	CAP. CERAMIC	3P	0.25P	50V
C068	CC45CH1H030C	CAP. CERAMIC	3P	0.25P	50V
C069	CC45CH1H470J	CAP. CERAMIC	47P	5%	50V
C070	NO USE				
C071	C91-0769-05	CAP. CERAMIC	0.01	20%	16V
C072	CC45CH1H470J	CAP. CERAMIC	47P	5%	50V
C073	CE04EW1C330M	CAP. ELECTRO	33	20%	16V
C074	NO USE				
C075	CC45CH1H150J	CAP. CERAMIC	15P	5%	50V
C076	CE04EW1C330M	CAP. ELECTRO	33	20%	16V
C077	CE04EW1C330M	CAP. ELECTRO	33	20%	16V
C078	CE04EW1C330M	CAP. ELECTRO	33	20%	16V
C079	CE04EW2A3R3M				
C080	CE04EW1C330M	CAP. ELECTRO	33	20%	16V
C081	CE04EW1C330M	CAP. ELECTRO	33	20%	16V
C082	NO USE				
C083	C91-0769-05	CAP. CERAMIC	0.01	20%	16V
C084	C91-0769-05	CAP. CERAMIC	0.01	20%	16V
C085	CE04EW1C330M	CAP. ELECTRO	33	20%	16V
C086	C91-0769-05	CAP. CERAMIC	0.01	20%	16V
C087	NO USE				
C088	CE04EW1C330M	CAP. ELECTRO	33	20%	16V
C089	CE04EW1C330M	CAP. ELECTRO	33	20%	16V
C090	NO USE				
C091	CE04BW1H010M	CAP. ELECTRO	1	20%	50V
C092	CC45CH1H101J	CAP. CERAMIC	100P	5%	50V
C093	CC45CH1H101J	CAP. CERAMIC	100P	5%	50V
C094	CC45SL1H221J	CAP. CERAMIC	220P	5%	50V
C095	CE04W2C3R3M	CAP. ELECTRO	3.3	20%	160V
C096	CK45B2H472K	CAP. CERAMIC	4700P	10%	500V
C097	C91-0769-05	CAP. CERAMIC	0.01	20%	16V
C098	C91-0769-05	CAP. CERAMIC	0.01	20%	16V
C099	C91-0769-05	CAP. CERAMIC	0.01	20%	16V
C100	C91-0769-05	CAP. CERAMIC	0.01	20%	16V
C101	C092M1H104K	CAP. MYLAR	0.1	10%	50V
C105	C91-0769-05	CAP. CERAMIC	0.01	20%	16V
C106	C91-0769-05	CAP. CERAMIC	0.01	20%	16V
C107	C91-0769-05	CAP. CERAMIC	0.01	20%	16V
C108	C092FM1H104K	CAP. MYLAR	0.1	10%	50V
C109	NO USE				
C110	C91-0769-05	CAP. CERAMIC	0.01	20%	16V
C111	C91-0769-05	CAP. CERAMIC	0.01	20%	16V
C114	CC45CH1H470J	CAP. CERAMIC	47P	5%	50V
C115	CE04EW1C330M	CAP. ELECTRO	33	20%	16V
C116	CE04EW1C330M	CAP. ELECTRO	33	20%	16V
C117	NO USE				
C118	CE04EW1C330M	CAP. ELECTRO	33	20%	16V
C119	CE04EW1C330M	CAP. ELECTRO	33	20%	16V

REF.NO	PARTS NO	NAME & DESCRIPTION			
C122	C092FM1H223K	CAP. MYLAR	0.022	10%	50V
C123	NO USE				
C124	CC45CH1H030C	CAP. CERAMIC	3P	0.25P	50V
C127	CK45F1H103Z	CAP. CERAMIC	0.01		50V
C128	CK45F1H103Z	CAP. CERAMIC	0.01		50V
C129	C91-0769-05	CAP. CERAMIC	0.01	20%	16V
C130	CE04EW1C100M	CAP. ELECTRO	10	20%	16V
C131	CC45CH1H010C	CAP. CERAMIC	1P	0.25P	50V
C132	CC45CH1H010C	CAP. CERAMIC	1P	0.25P	50V
C133	CC45CH1H030C	CAP. CERAMIC	3P	0.25P	50V
C134	CC45CH1H030C	CAP. CERAMIC	3P	0.25P	50V
D001	1SS132	DIODE			
D002	1SS132	DIODE			
D003	1SS132	DIODE			
D004	1SS132	DIODE			
D005	1SS132	DIODE			
D006	1SS132	DIODE			
D007	1SS132	DIODE			
D008	1SS132	DIODE			
D009	1SS132	DIODE			
D010	1SS132	DIODE			
D011	1SS132	DIODE			
D012	1SS132	DIODE			
D013	1SS132	DIODE			
D014	1SS132	DIODE			
D015	1SS132	DIODE			
D016	1SS132	DIODE			
D017	NO USE				
D018	1SS132	DIODE			
D021	1SS132	DIODE			
D022	1SS132	DIODE			
D023	1SS132	DIODE			
D024	1SS132	DIODE			
D025	MT27.5JA	DIODE, ZENER	9.6V		
D026	1SS132	DIODE			
D027	1SS132	DIODE			
D028	1SS132	DIODE			
D029	1SS132	DIODE			
D030	1SS132	DIODE			
D031	1SS132	DIODE			
D032	1SSB3	DIODE			
D033	1SSB3	DIODE			
D034	1SSB3	DIODE			
D035	1SS132	DIODE			
D036	MT27.5JA	DIODE, ZENER	9.6V		
J005	E31-2615-05	LEAD WIRE WITH CONNECTOR			
J025	E31-2669-05	LEAD WIRE WITH CONNECTOR			
J026	E31-2671-05	LEAD WIRE WITH CONNECTOR			
J031	E31-2677-05	LEAD WIRE WITH CONNECTOR			
J034	E31-2699-05	LEAD WIRE WITH CONNECTOR			
J043	E31-2707-05	LEAD WIRE WITH CONNECTOR			
L001	L40-6801-03	FERRI INDUCTOR	68UH		
L002	L40-4701-03	FERRI INDUCTOR	47UH (SH)		
L003	L40-4701-03	FERRI INDUCTOR	47UH (SH)		
P002	E40-0374-05	PIN CONNECTOR	3P		
P007	E40-0273-05	PIN CONNECTOR	2P		
P008	E40-0273-05	PIN CONNECTOR	2P		
P009	E40-0874-05	PIN CONNECTOR	8P		
P010	E40-0273-05	PIN CONNECTOR	2P		
P011	E40-0373-05	PIN CONNECTOR	3P		
P012	NO USE				
P013	E40-1373-05	PIN CONNECTOR	13P		
P014	NO USE				
P015	E40-0373-05	PIN CONNECTOR	3P		
P018	E40-0273-05	PIN CONNECTOR	2P		
P025	E40-0573-05	PIN CONNECTOR	5P		
P026	E40-0873-05	PIN CONNECTOR	8P		
P027	E40-0573-05	PIN CONNECTOR	5P		
P031	E40-0573-05	PIN CONNECTOR	5P		
Q001	2SK241(Y)	FET. N-CHANNEL, MOS			
Q002	2SK241(Y)	FET. N-CHANNEL, MOS			
Q003	2SC2786(K)	TR. SI, NPN			



# PARTS LIST

REF. NO	PARTS NO	NAME & DESCRIPTION	REF. NO	PARTS NO	NAME & DESCRIPTION
Q004	2SA1005(K)	TR. SI, PNP	R026	RD14BB2C132J	RES. CARBON 1.3K 5% 1/6W
Q005	2SC2785(F)	TR. SI, NPN	R027	RD14BB2C680J	RES. CARBON 68 5% 1/6W
Q006	2SC1215(S, T)	TR. SI, NPN	R028	RD14BB2C102J	RES. CARBON 1K 5% 1/6W
Q007	2SC1215(S, T)	TR. SI, NPN	R029	RD14BB2C102J	RES. CARBON 1K 5% 1/6W
Q008	2SC2785(F)	TR. SI, NPN			
Q009	2SC2785(F)	TR. SI, NPN	R032	RD14BB2E432J	RES. CARBON 4.3K 5% 1/4W
Q010	2SC2786(K)	TR. SI, NPN	R033	RD14BB2C511J	RES. CARBON 510 5% 1/6W
Q013	2SA1175(F)	TR. SI, PNP	R036	RD14BB2E431J	RES. CARBON 430 5% 1/4W
Q014	2SA1005(K)	TR. SI, PNP	R037	RD14BB2C472J	RES. CARBON 4.7K 5% 1/6W
Q015	2SA1175(F)	TR. SI, PNP	R038	RD14BB2C223J	RES. CARBON 22K 5% 1/6W
Q016	2SK117(Y)	FET. N-CHANNEL	R039	RD14BB2E103J	RES. CARBON 10K 5% 1/4W
Q017	2SC2785(F)	TR. SI, NPN	R040	NO USE	
Q018	2SA1175(F)	TR. SI, PNP	R041	RD14BB2C472J	RES. CARBON 4.7K 5% 1/6W
Q019	2SK161(GR)	FET. N-CHANNEL	R042	RD14BB2C103J	RES. CARBON 10K 5% 1/6W
Q020	2SC2785(F)	TR. SI, NPN	R043	RD14BB2C472J	RES. CARBON 4.7K 5% 1/6W
Q021	2SC2785(F)	TR. SI, NPN	R044	RD14BB2C103J	RES. CARBON 10K 5% 1/6W
Q022	2SA1175(F)	TR. SI, PNP	R045	RD14BB2C103J	RES. CARBON 10K 5% 1/6W
Q023	2SC2785(F)	TR. SI, NPN	R046	RD14BB2C102J	RES. CARBON 1K 5% 1/6W
Q024	2SA1175(F)	TR. SI, PNP	R047	RD14BB2C102J	RES. CARBON 1K 5% 1/6W
Q025	2SA1175(F)	TR. SI, PNP	R048	RD14BB2C102J	RES. CARBON 1K 5% 1/6W
Q026	2SA1005(K)	TR. SI, PNP	R049	RD14BB2C102J	RES. CARBON 1K 5% 1/6W
Q027	2SA1175(F)	TR. SI, PNP	R050	RD14BB2C102J	RES. CARBON 1K 5% 1/6W
Q028	2SK117(Y)	FET. N-CHANNEL	R051	RD14BB2C472J	RES. CARBON 4.7K 5% 1/6W
Q029	2SC2785(F)	TR. SI, NPN	R052	RD14BB2C472J	RES. CARBON 4.7K 5% 1/6W
Q030	2SA1175(F)	TR. SI, PNP	R053	RD14BB2E472J	RES. CARBON 4.7K 5% 1/4W
Q031	2SK161(GR)	FET. N-CHANNEL	R054	RD14BB2C102J	RES. CARBON 1K 5% 1/6W
Q032	2SA1175(F)	TR. SI, PNP	R055	RD14BB2C102J	RES. CARBON 1K 5% 1/6W
Q033	2SC3066(F, G)	TR. SI, NPN	R056	RD14BB2C154J	RES. CARBON 150K 5% 1/6W
Q034	2SC2785(F)	TR. SI, NPN	R057	RD14BB2C101J	RES. CARBON 100 5% 1/6W
Q035	2SC2785(F)	TR. SI, NPN	R058	RD14BB2C103J	RES. CARBON 10K 5% 1/6W
Q036	2SC2785(F)	TR. SI, NPN	R059	RD14BB2C472J	RES. CARBON 4.7K 5% 1/6W
Q037	2SC2786(K)	TR. SI, NPN	R060	RD14BB2C472J	RES. CARBON 4.7K 5% 1/6W
Q038	2SC2786(K)	TR. SI, NPN	R061	RD14BB2C472J	RES. CARBON 4.7K 5% 1/6W
Q039	2SC2785(F)	TR. SI, NPN	R062	RD14BB2C102J	RES. CARBON 1K 5% 1/6W
Q040	2SC2785(F)	TR. SI, NPN	R063	RD14BB2C102J	RES. CARBON 1K 5% 1/6W
Q041	2SC2786(K)	TR. SI, NPN	R064	RD14BB2C102J	RES. CARBON 1K 5% 1/6W
Q042	2SC2785(F)	TR. SI, NPN	R065	RD14BB2C472J	RES. CARBON 4.7K 5% 1/6W
Q043	2SA1005(K)	TR. SI, PNP	R066	RD14BB2C102J	RES. CARBON 1K 5% 1/6W
Q044	2SK336	FET. N-CHANNEL	R067	RD14BB2C102J	RES. CARBON 1K 5% 1/6W
Q045	2SK336	FET. N-CHANNEL	R068	RD14BB2C102J	RES. CARBON 1K 5% 1/6W
Q046	2SA1005(K)	TR. SI, PNP	R069	RD14BB2C102J	RES. CARBON 1K 5% 1/6W
Q047	2SC2785(F)	TR. SI, NPN	R070	RD14BB2C102J	RES. CARBON 1K 5% 1/6W
Q048	2SC2785(F)	TR. SI, NPN	R071	RD14BB2C472J	RES. CARBON 4.7K 5% 1/6W
Q049	2SC2912(S)	TR. SI, NPN	R072	RD14BB2C102J	RES. CARBON 1K 5% 1/6W
Q050	2SC2912(S)	TR. SI, NPN	R073	RD14BB2C102J	RES. CARBON 1K 5% 1/6W
Q051	2SA1210(S)	TR. SI, PNP	R074	RD14BB2C102J	RES. CARBON 1K 5% 1/6W
Q052	2SA1210(S)	TR. SI, PNP	R075	RD14BB2C102J	RES. CARBON 1K 5% 1/6W
			R076	RD14BB2C102J	RES. CARBON 1K 5% 1/6W
Q059	2SC2785(F)	TR. SI, NPN	R077	RD14BB2E472J	RES. CARBON 4.7K 5% 1/4W
Q060	2SA1175(F)	TR. SI, PNP	R078	RD14BB2C102J	RES. CARBON 1K 5% 1/6W
Q061	2SA1005(K)	TR. SI, PNP	R079	RD14BB2C102J	RES. CARBON 1K 5% 1/6W
Q062	2SC2786(K)	TR. SI, NPN	R080	RD14BB2C102J	RES. CARBON 1K 5% 1/6W
Q063	2SA1005(K)	TR. SI, PNP	R081	RD14BB2C101J	RES. CARBON 100 5% 1/6W
Q064	2SC2785(F)	TR. SI, NPN	R082	RD14BB2C221J	RES. CARBON 220 5% 1/6W
Q065	2SA1175(F)	TR. SI, PNP	R083	RD14BB2C472J	RES. CARBON 4.7K 5% 1/6W
Q066	2SA1005(K)	TR. SI, PNP	R084	RD14BB2C222J	RES. CARBON 2.2K 5% 1/6W
Q067	2SC2785(F)	TR. SI, NPN	R085	RD14BB2C472J	RES. CARBON 4.7K 5% 1/6W
Q068	2SA1175(F)	TR. SI, PNP	R086	RD14BB2C222J	RES. CARBON 2.2K 5% 1/6W
Q069	2SC2785(F)	TR. SI, NPN	R087	RD14BB2C222J	RES. CARBON 2.2K 5% 1/6W
Q070	2SC2785(F)	TR. SI, NPN	R088	RD14BB2C222J	RES. CARBON 2.2K 5% 1/6W
Q071	2SC2785(F)	TR. SI, NPN	R089	RD14BB2C472J	RES. CARBON 4.7K 5% 1/6W
			R090	RD14BB2C111J	RES. CARBON 110 5% 1/6W
R001	RD14BB2C104J	RES. CARBON 100K 5% 1/6W	R091	RD14BB2C222J	RES. CARBON 2.2K 5% 1/6W
R002	RD14BB2C914J	RES. CARBON 910K 5% 1/6W	R092	RD14BB2C102J	RES. CARBON 1K 5% 1/6W
R003	RD14BB2C470J	RES. CARBON 47 5% 1/6W	R093	RD14BB2C331J	RES. CARBON 330 5% 1/6W
R004	RD14BB2C220J	RES. CARBON 22 5% 1/6W	R094	RD14BB2C153J	RES. CARBON 15K 5% 1/6W
R005	RD14BB2C470J	RES. CARBON 47 5% 1/6W	R095	RS14GB3A472J	RES. METAL FILM 4.7K 5% 1W
R006	RD14BB2C162J	RES. CARBON 1.6K 5% 1/6W	R096	RD14BB2C153J	RES. CARBON 15K 5% 1/6W
R007	RD14BB2C103J	RES. CARBON 10K 5% 1/6W	R097	RD14BB2C821J	RES. CARBON 820 5% 1/6W
R008	RD14BB2C332J	RES. CARBON 3.3K 5% 1/6W	R098	RD14BB2C272J	RES. CARBON 2.7K 5% 1/6W
R009	RD14BB2C331J	RES. CARBON 330 5% 1/6W	R099	RD14BB2C153J	RES. CARBON 15K 5% 1/6W
R010	RD14BB2C911J	RES. CARBON 910 5% 1/6W	R100	RD14BB2C472J	RES. CARBON 4.7K 5% 1/6W
R011	RN14BK2C9103F	RES. METAL FILM 910K 1% 1/6W	R101	RD14BB2C911J	RES. CARBON 910 5% 1/6W
R012	RN14BK2C9103F	RES. METAL FILM 910K 1% 1/6W	R102	RN14BK2H3004F	RES. METAL FILM 3M 1% 1/2W
R013	RD14BB2C102J	RES. CARBON 1K 5% 1/6W	R103	RN14BK2E1004F	RES. METAL FILM 1M 1% 1/4W
R014	RD14BB2C152J	RES. CARBON 1.5K 5% 1/6W	R104	RN14BK2ES003F	RES. METAL FILM 500K 1% 1/4W
R015	RD14BB2C105J	RES. CARBON 1M 5% 1/6W	R105	RN14BK2E3003F	RES. METAL FILM 300K 1% 1/4W
R016	RD14BB2C473J	RES. CARBON 47K 5% 1/6W	R106	RN14BK2E1003F	RES. METAL FILM 100K 1% 1/4W
R017	RD14BB2E220J	RES. CARBON 22 5% 1/4W	R107	RN14BK2E4992F	RES. METAL FILM 49.9K 1% 1/4W
R018	RD14BB2C332J	RES. CARBON 3.3K 5% 1/6W	R108	R92-1066-05	RES. METAL FILM 29.8K 1% 1/4W
R019	RD14BB2C220J	RES. CARBON 22 5% 1/6W	R109	R92-1065-05	RES. METAL FILM 9.92K 1% 1/4W
R020	RD14BB2C102J	RES. CARBON 1K 5% 1/6W	R110	R92-1064-05	RES. METAL FILM 4.95K 1% 1/4W
R021	RD14BB2C472J	RES. CARBON 4.7K 5% 1/6W	R111	R92-1064-05	RES. METAL FILM 4.95K 1% 1/4W
R022	RD14BB2C912J	RES. CARBON 9.1K 5% 1/6W	R112	RN14BK2E2202F	RES. METAL FILM 22K 1% 1/4W
R023	RD14BB2C472J	RES. CARBON 4.7K 5% 1/6W	R113	RN14BK2C2002F	RES. METAL FILM 20K 1% 1/6W
R024	RD14BB2C103J	RES. CARBON 10K 5% 1/6W	R114	RD14BB2C182J	RES. CARBON 1.8K 5% 1/6W
R025	RD14BB2C132J	RES. CARBON 1.3K 5% 1/6W	R115	RD14BB2C332J	RES. CARBON 3.3K 5% 1/6W

# PARTS LIST

REF.NO	PARTS NO	NAME & DESCRIPTION			
R116	RD14BB2C103J	RES. CARBON	10K	5%	1/6W
R117	RD14BB2C102J	RES. CARBON	1K	5%	1/6W
R118	RD14BB2C222J	RES. CARBON	2.2K	5%	1/6W
R119	RD14BB2E331J	RES. CARBON	330	5%	1/4W
R120	RD14BB2C102J	RES. CARBON	1K	5%	1/6W
R121	RD14BB2C221J	RES. CARBON	220	5%	1/6W
R122	RD14BB2C472J	RES. CARBON	4.7K	5%	1/6W
R123	RD14BB2C472J	RES. CARBON	4.7K	5%	1/6W
R124	RD14BB2C472J	RES. CARBON	4.7K	5%	1/6W
R125	RD14BB2C472J	RES. CARBON	4.7K	5%	1/6W
R126	RD14BB2C103J	RES. CARBON	10K	5%	1/6W
R127	RD14BB2C472J	RES. CARBON	4.7K	5%	1/6W
R128	RS14GB3A472J	RES. METAL FILM	4.7K	5%	1W
R129	RD14BB2C153J	RES. CARBON	15K	5%	1/6W
R130	RD14BB2C153J	RES. CARBON	15K	5%	1/6W
R131	RD14BB2C472J	RES. CARBON	4.7K	5%	1/6W
R132	RD14BB2C332J	RES. CARBON	3.3K	5%	1/6W
R133	RN14BK2H3004F	RES. METAL FILM	3M	1%	1/2W
R134	RN14BK2E1004F	RES. METAL FILM	1M	1%	1/4W
R135	RN14BK2E5003F	RES. METAL FILM	500K	1%	1/4W
R136	RN14BK2E3003F	RES. METAL FILM	300K	1%	1/4W
R137	RN14BK2E1003F	RES. METAL FILM	100K	1%	1/4W
R138	RN14BK2E4992F	RES. METAL FILM	49.9K	1%	1/4W
R139	R92-1066-05	RES. METAL FILM	29.8K	1%	1/4W
R140	R92-1065-05	RES. METAL FILM	9.92K	1%	1/4W
R141	R92-1064-05	RES. METAL FILM	4.95K	1%	1/4W
R142	R92-1064-05	RES. METAL FILM	4.95K	1%	1/4W
R143	RN14BK2C2202F	RES. METAL FILM	22K	1%	1/6W
R144	RN14BK2E2002F	RES. METAL FILM	20K	1%	1/4W
R145	RD14BB2C332J	RES. CARBON	3.3K	5%	1/6W
R146	RD14BB2C182J	RES. CARBON	1.8K	5%	1/6W
R147	RD14BB2C113J	RES. CARBON	11K	5%	1/6W
R148	RD14BB2C912J	RES. CARBON	9.1K	5%	1/6W
R149	RD14BB2C101J	RES. CARBON	100	5%	1/6W
R150	RD14BB2C472J	RES. CARBON	4.7K	5%	1/6W
R151	RD14BB2C623J	RES. CARBON	62K	5%	1/6W
R152	RD14BB2C102J	RES. CARBON	1K	5%	1/6W
R153	RD14BB2C361J	RES. CARBON	360	5%	1/6W
R154	RD14BB2C822J	RES. CARBON	8.2K	5%	1/6W
R155	RD14BB2C152J	RES. CARBON	1.5K	5%	1/6W
R156	RD14BB2C103J	RES. CARBON	10K	5%	1/6W
R157	RD14BB2E103J	RES. CARBON	10K	5%	1/4W
R158	RD14BB2C472J	RES. CARBON	4.7K	5%	1/6W
R159	RD14BB2C163J	RES. CARBON	16K	5%	1/6W
R160	RD14BB2C101J	RES. CARBON	100	5%	1/6W
R161	RD14BB2C101J	RES. CARBON	100	5%	1/6W
R162	RD14BB2C432J	RES. CARBON	4.3K	5%	1/6W
R163	RD14BB2E152J	RES. CARBON	1.5K	5%	1/4W
R164	NO USE				
R165	RD14BB2C103J	RES. CARBON	10K	5%	1/6W
R166	RD14BB2C432J	RES. CARBON	4.3K	5%	1/6W
R167	RD14BB2C101J	RES. CARBON	100	5%	1/6W
R168	RD14BB2C103J	RES. CARBON	10K	5%	1/6W
R169	RD14BB2E392J	RES. CARBON	3.9K	5%	1/4W
R170	RD14BB2C101J	RES. CARBON	100	5%	1/6W
R171	NO USE				
R172	RD14BB2C331J	RES. CARBON	330	5%	1/6W
R173	RD14BB2C331J	RES. CARBON	330	5%	1/6W
R174	RD14BB2C182J	RES. CARBON	1.8K	5%	1/6W
R175	RD14BB2C182J	RES. CARBON	1.8K	5%	1/6W
R176	RD14BB2C273J	RES. CARBON	27K	5%	1/6W
R177	RD14BB2C104J	RES. CARBON	100K	5%	1/6W
R178	NO USE				
R179	RD14BB2C101J	RES. CARBON	100	5%	1/6W
R180	RD14BB2C101J	RES. CARBON	100	5%	1/6W
R181	RN14BK2C3301F	RES. METAL FILM	3.3K	1%	1/6W
R182	RN14BK2E3301F	RES. METAL FILM	3.3K	1%	1/4W
R183	RD14BB2C271J	RES. CARBON	270	5%	1/6W
R184	RD14BB2C271J	RES. CARBON	270	5%	1/6W
R185	RD14BB2C102J	RES. CARBON	1K	5%	1/6W
R186	RD14BB2C102J	RES. CARBON	1K	5%	1/6W
R187	RD14BB2E103J	RES. CARBON	10K	5%	1/4W
R188	RN14BK2E6802F	RES. METAL FILM	68K	1%	1/4W
R189	RN14BK2E6802F	RES. METAL FILM	68K	1%	1/4W
R190	RN14BK2C1001F	RES. METAL FILM	1K	1%	1/6W
R191	RN14BK2C1001F	RES. METAL FILM	1K	1%	1/6W
R192	RD14DB3A183J	RES. CARBON	18K	5%	1W
R193	RD14BB2C102J	RES. CARBON	1K	5%	1/6W
R194	RD14BB2E220J	RES. CARBON	22	5%	1/4W
R195	RD14BB2C102J	RES. CARBON	1K	5%	1/6W
R196	RD14BB2C102J	RES. CARBON	1K	5%	1/6W
R197	RD14BB2C102J	RES. CARBON	1K	5%	1/6W
R198	RD14BB2E183J	RES. CARBON	18K	5%	1/4W
R199	RD14BB2C102J	RES. CARBON	1K	5%	1/6W
R200	RD14BB2C102J	RES. CARBON	1K	5%	1/6W
R208	RD14BB2C222J	RES. CARBON	2.2K	5%	1/6W
R209	RD14BB2C331J	RES. CARBON	330	5%	1/6W

REF.NO	PARTS NO	NAME & DESCRIPTION			
R210	RD14BB2C102J	RES. CARBON	1K	5%	1/6W
R211	RD14BB2C102J	RES. CARBON	1K	5%	1/6W
R212	RD14BB2C111J	RES. CARBON	110	5%	1/6W
R213	RD14BB2C103J	RES. CARBON	10K	5%	1/6W
R214	RD14BB2C103J	RES. CARBON	10K	5%	1/6W
R215	RD14BB2C912J	RES. CARBON	9.1K	5%	1/6W
R216	RD14BB2C912J	RES. CARBON	9.1K	5%	1/6W
R217	RD14BB2C332J	RES. CARBON	3.3K	5%	1/6W
R218	RD14BB2C332J	RES. CARBON	3.3K	5%	1/6W
R219	RD14BB2C223J	RES. CARBON	22K	5%	1/6W
R220	RD14BB2C472J	RES. CARBON	4.7K	5%	1/6W
R221	RD14BB2C472J	RES. CARBON	4.7K	5%	1/6W
R222	RD14BB2C472J	RES. CARBON	4.7K	5%	1/6W
R223	RD14BB2C101J	RES. CARBON	100	5%	1/6W
R224	RD14BB2C202J	RES. CARBON	2K	5%	1/6W
R225	RD14BB2C220J	RES. CARBON	22	5%	1/6W
R226	RD14BB2C392J	RES. CARBON	3.9K	5%	1/6W
R227	RD14BB2C133J	RES. CARBON	13K	5%	1/6W
R228	RD14BB2C104J	RES. CARBON	100K	5%	1/6W
R229	RD14BB2C394J	RES. CARBON	390K	5%	1/6W
R230	RD14BB2C333J	RES. CARBON	33K	5%	1/6W
R231	RD14BB2C244J	RES. CARBON	240K	5%	1/6W
R232	RD14BB2C820J	RES. CARBON	82	5%	1/6W
R233	RD14BB2C222J	RES. CARBON	2.2K	5%	1/6W
R234	RD14BB2C103J	RES. CARBON	10K	5%	1/6W
R235	RD14BB2C103J	RES. CARBON	10K	5%	1/6W
R236	RD14BB2C301J	RES. CARBON	300	5%	1/6W
R237	RD14BB2C103J	RES. CARBON	10K	5%	1/6W
R238	RD14BB2E103J	RES. CARBON	10K	5%	1/4W
R239	RD14BB2E103J	RES. CARBON	10K	5%	1/4W
R240	RD14BB2C103J	RES. CARBON	10K	5%	1/6W
R241	RD14BB2C122J	RES. CARBON	1.2K	5%	1/6W
R242	RD14BB2C122J	RES. CARBON	1.2K	5%	1/6W
R243	RD14BB2E151J	RES. CARBON	150	5%	1/4W
R244	RD14BB2E362J	RES. CARBON	3.6K	5%	1/4W
R245	RD14BB2C103J	RES. CARBON	10K	5%	1/6W
R246	RD14BB2C103J	RES. CARBON	10K	5%	1/6W
R247	RD14BB2C103J	RES. CARBON	10K	5%	1/6W
R248	RD14BB2C103J	RES. CARBON	10K	5%	1/6W
R249	RD14BB2C103J	RES. CARBON	10K	5%	1/6W
R250	RD14BB2E103J	RES. CARBON	10K	5%	1/4W
R251	RD14BB2C103J	RES. CARBON	10K	5%	1/6W
R252	RD14BB2C103J	RES. CARBON	10K	5%	1/6W
R253	RD14BB2C103J	RES. CARBON	10K	5%	1/6W
R254	RD14BB2E220J	RES. CARBON	22	5%	1/4W
R255	RD14BB2C103J	RES. CARBON	10K	5%	1/6W
R256	RD14BB2C111J	RES. CARBON	110	5%	1/6W
R257	RN14BK2C6800F	RES. METAL FILM	680	1%	1/6W
R258	RN14BK2C1601F	RES. METAL FILM	1.6K	1%	1/6W
R259	RN14BK2C5100F	RES. METAL FILM	510	1%	1/6W
R260	RD14BB2E202J	RES. CARBON	2K	5%	1/4W
R261	RD14BB2C102J	RES. CARBON	1K	5%	1/6W
R262	NO USE				
R263	RD14BB2C472J	RES. CARBON	4.7K	5%	1/6W
R264	RD14BB2C101J	RES. CARBON	100	5%	1/6W
R265	RD14BB2C332J	RES. CARBON	3.3K	5%	1/6W
R266	RD14BB2C105J	RES. CARBON	1M	5%	1/6W
R267	RD14BB2E622J	RES. CARBON	6.2K	5%	1/4W
R268	RD14BB2C332J	RES. CARBON	3.3K	5%	1/6W
R269	RD14BB2C134J	RES. CARBON	130K	5%	1/6W
R270	RD14BB2E181J	RES. CARBON	180	5%	1/4W
R271	RD14BB2C101J	RES. CARBON	100	5%	1/6W
R272	RD14BB2C101J	RES. CARBON	100	5%	1/6W
R273	RD14BB2E102J	RES. CARBON	1K	5%	1/4W
R274	RD14BB2C101J	RES. CARBON	100	5%	1/6W
R275	RD14BB2C470J	RES. CARBON	47	5%	1/6W
R276	RD14BB2C103J	RES. CARBON	10K	5%	1/6W
R277	RD14BB2E912J	RES. CARBON	9.1K	5%	1/4W
R278	NO USE				
R279	RD14BB2C203J	RES. CARBON	20K	5%	1/6W
R280	RD14BB2E622J	RES. CARBON	6.2K	5%	1/4W
R281	RD14BB2C222J	RES. CARBON	2.2K	5%	1/6W
R282	RD14BB2C471J	RES. CARBON	470	5%	1/6W
R283	RD14BB2C101J	RES. CARBON	100	5%	1/6W
R284	RD14BB2C472J	RES. CARBON	4.7K	5%	1/6W
R285	RD14BB2C183J	RES. CARBON	18K	5%	1/6W
R286	NO USE				
R287	RD14BB2C472J	RES. CARBON	4.7K	5%	1/6W
R288	RD14BB2E101J	RES. CARBON	100	5%	1/4W
R289	RD14BB2C102J	RES. CARBON	1K	5%	1/6W
R290	RD14BB2C101J	RES. CARBON	100	5%	1/6W
S001	S32-4008-05	LEVER SWITCH 4-5			
S002	S33-4503-05	LEVER SWITCH 4-5 (H.MODE)			
S003	S01-5505-05	ROTARY SWITCH			
S004	S37-2005-05	LEVER SWITCH 2-4 (TRIG SOURCE)			
S005	S37-2005-05	LEVER SWITCH 2-4 (TRIG SOURCE)			

# PARTS LIST

REF.NO	PARTS NO	NAME & DESCRIPTION
S006	S33-2501-05	LEVER SWITCH 2-5
TC001	C05-0445-05	CAP. TRIMMER 20P
TC002	C05-0445-05	CAP. TRIMMER 20P
TC003	NO USE	
TC004	C05-0445-05	CAP. TRIMMER 20P
TC005	C05-0445-05	CAP. TRIMMER 20P
U001	TL082CP	IC, OP AMP
U002	MC14081BĈP	IC, QUAD 2-INPUT AND GATE
U003	MC10105L	IC, TRIPLE 2-3-2-OR/NOR
U004	MC10107L	IC, TRIPLE 2 INPUT EXC OR/NOR
U005	MC10103L	IC, QUAD 2-INPUT OR GATE
U006	MC10131L	IC, DUAL D-FLIP FLOP
U007	MC10104L	IC, QUAD 2-INPUT AND GATE
U008	MC10105L	IC, TRIPLE 2-3-2-OR/NOR
U009	MC10103L	IC, QUAD 2-INPUT OR GATE
U010	MC10102L	IC, QUAD 2-INPUT NOR GATE
U011	SN74LS112AN	IC, DUAL JK-FF
U012	SN74LS10N	IC, TRIPLE 3-INPUT NAND GATE
U013	SN74LS00N	IC, QUAD 2-INPUT NAND GATE
U014	SN74LS08N	IC, QUAD 2-INPUT AND GATE
U015	SN74LS08N	IC, QUAD 2-INPUT AND GATE
U016	SN74LS257N	IC, QUAD DATA SELECTOR
U017	SN74LS32N	IC, QUAD 2-INPUT OR GATE
U018	SN74LS112AN	IC, DUAL JK-FF
VR001	R12-0563-05	RES. SEMI FIXED 500B
VR002	R12-0563-05	RES. SEMI FIXED 500B
VR003	R23-9503-05	V.R. 10K B, 2K B
VR004	R12-0563-05	RES. SEMI FIXED 500B
VR005	R12-2517-05	RES. SEMI FIXED 5K B
VR006	R12-3536-05	RES. SEMI FIXED 10K B
VR007	R12-2517-05	RES. SEMI FIXED 5K B
VR008	R12-0562-05	RES. SEMI FIXED 200 B
VR009	R12-1528-05	RES. SEMI FIXED 1K B
VR010	R12-2517-05	RES. SEMI FIXED 5K B
VR011	R12-1528-05	RES. SEMI FIXED 1K B
VR012	R01-1515-05	V.R. 2K B
VR013	R12-3537-05	RES. SEMI FIXED 20K B
VR014	R01-3514-05	V.R. 20KB (TRIG, H.POSI)
VR015	R23-3501-05	V.R. 10K X2
VR016	R12-3536-05	RES. SEMI FIXED 10K B
VR017	R23-9503-05	V.R. 10K B, 2K B
VR018	R23-3501-05	V.R. 10K X2
VR019	R10-9505-05	V.R. 1K/200K
VR020	R10-9505-05	V.R. 1K/200K

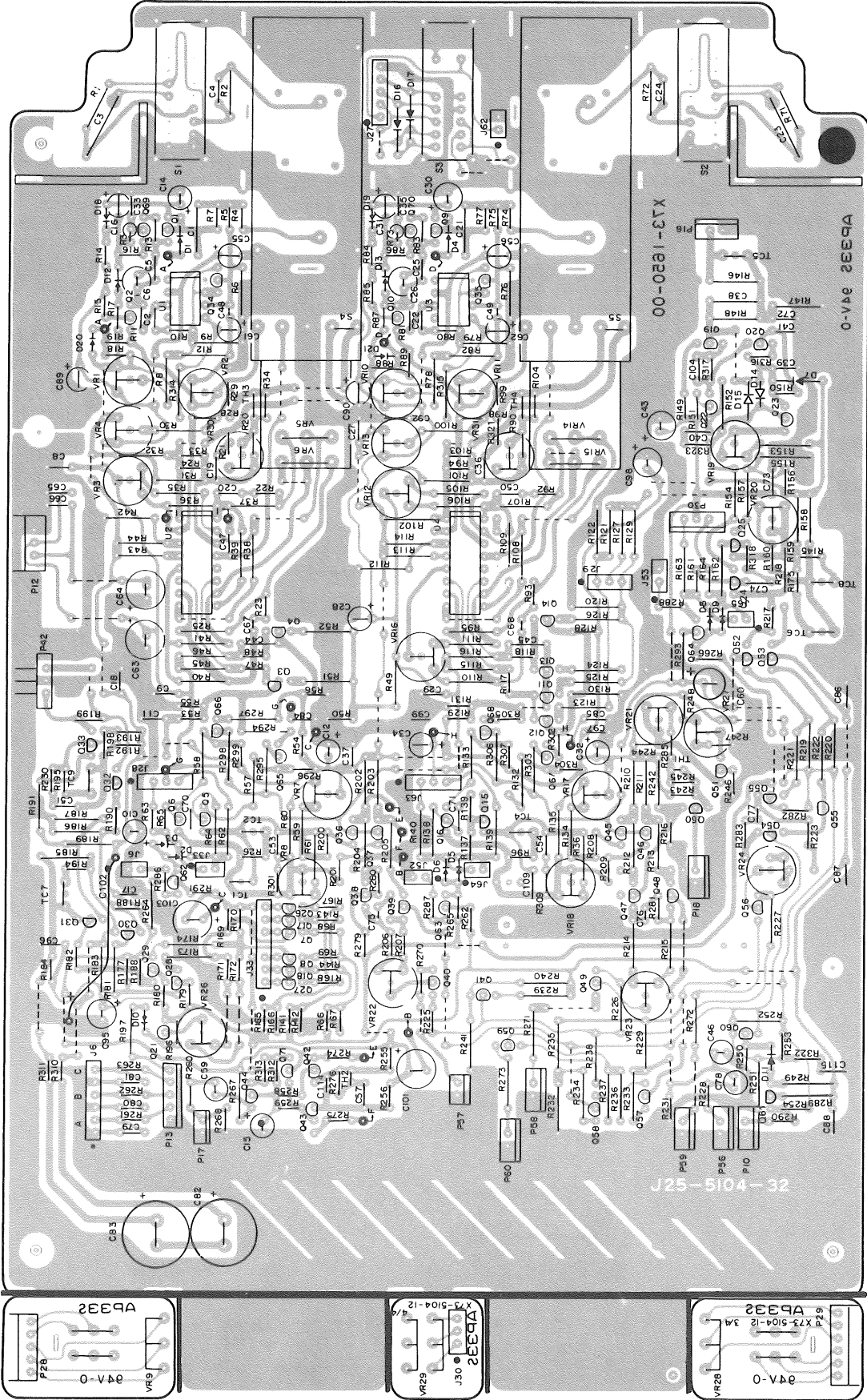
## CRT SOCKET UNIT

### X81-1600-00

REF.NO	PARTS NO	NAME & DESCRIPTION
	E01-0103-05	CRT SOCKET
	E23-0503-05	TERMINAL
	J25-5102-14	PCB (UNMOUNTED)
C001	CC45CH1H020C	CAP. CERAMIC 2P 0.25P 50V
C002	CC45CH1H010C	CAP. CERAMIC 1P 0.25P 50V
J001	E31-2611-05	LEAD WIRE WITH CONNECTOR
J002	E31-2612-05	LEAD WIRE WITH CONNECTOR
J003	NO USE	
J004	E31-2614-05	LEAD WIRE WITH CONNECTOR
L001	L40-4782-13	FERRI INDUCTOR 0.47UH 20%
L002	L40-4782-13	FERRI INDUCTOR 0.47UH 20%
R001	RD14BB2C301J	RES. CARBON 300 5% 1/6W
R002	RD14BB2C301J	RES. CARBON 300 5% 1/6W
R003	RD14BB2C6R8J	RES. CARBON 6.8 5% 1/6W
R004	RD14BB2E473J	RES. CARBON 47K 5% 1/4W

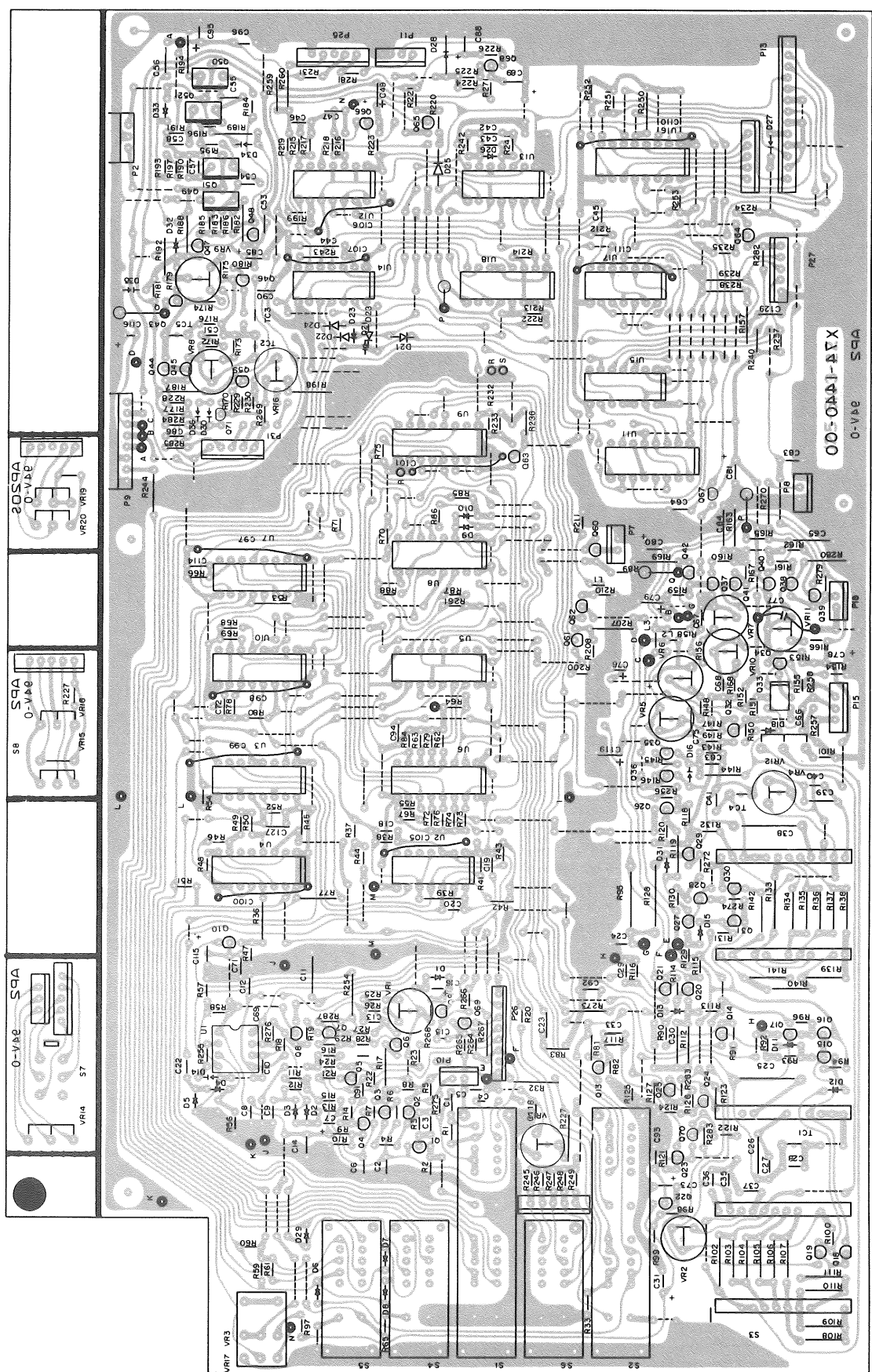


**VERTICAL PREAMP UNIT (X73-1650)**  
Foil side view



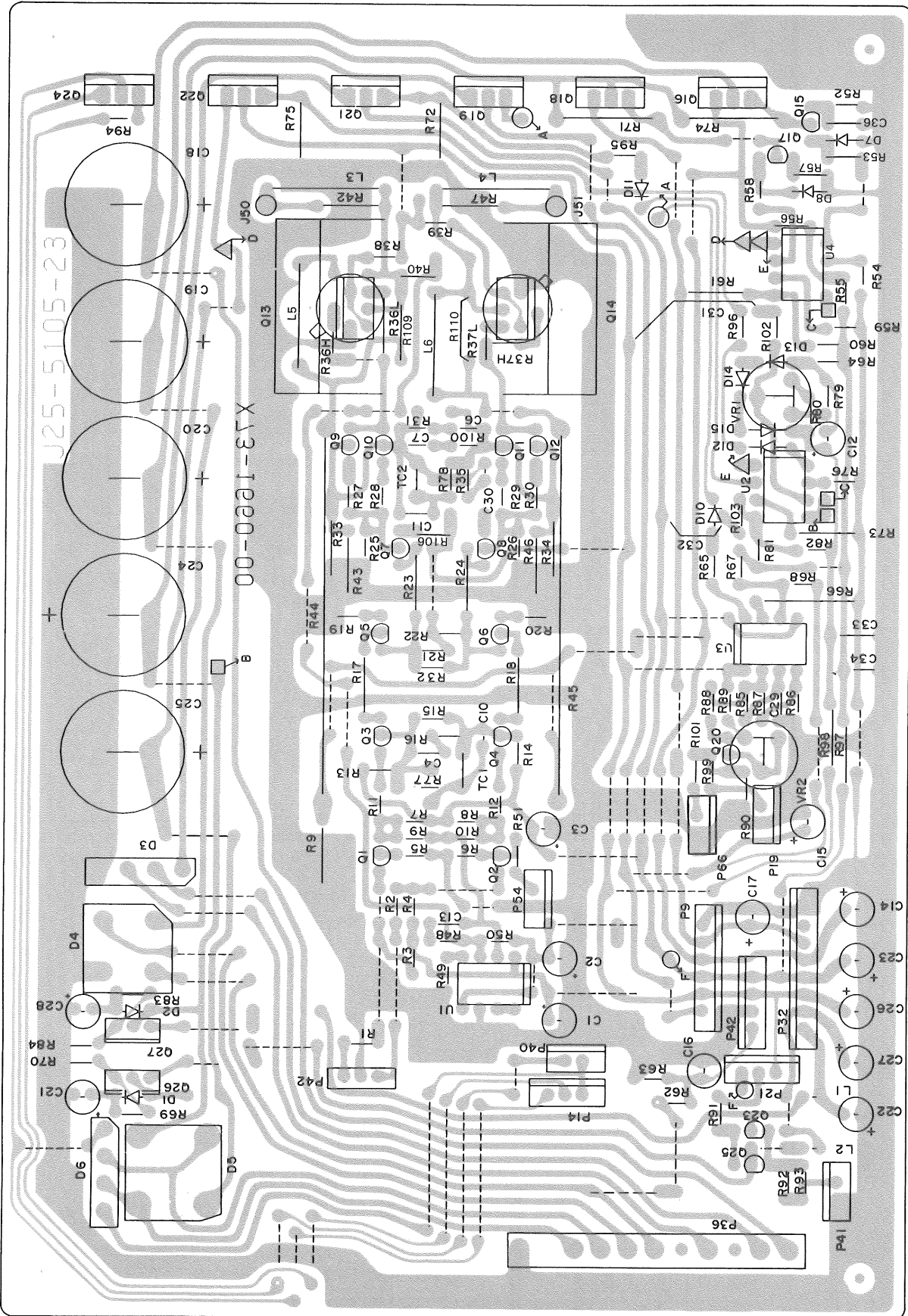
**P.C. BOARD**

**SWEEP UNIT (X74-1440)**  
Foil side view



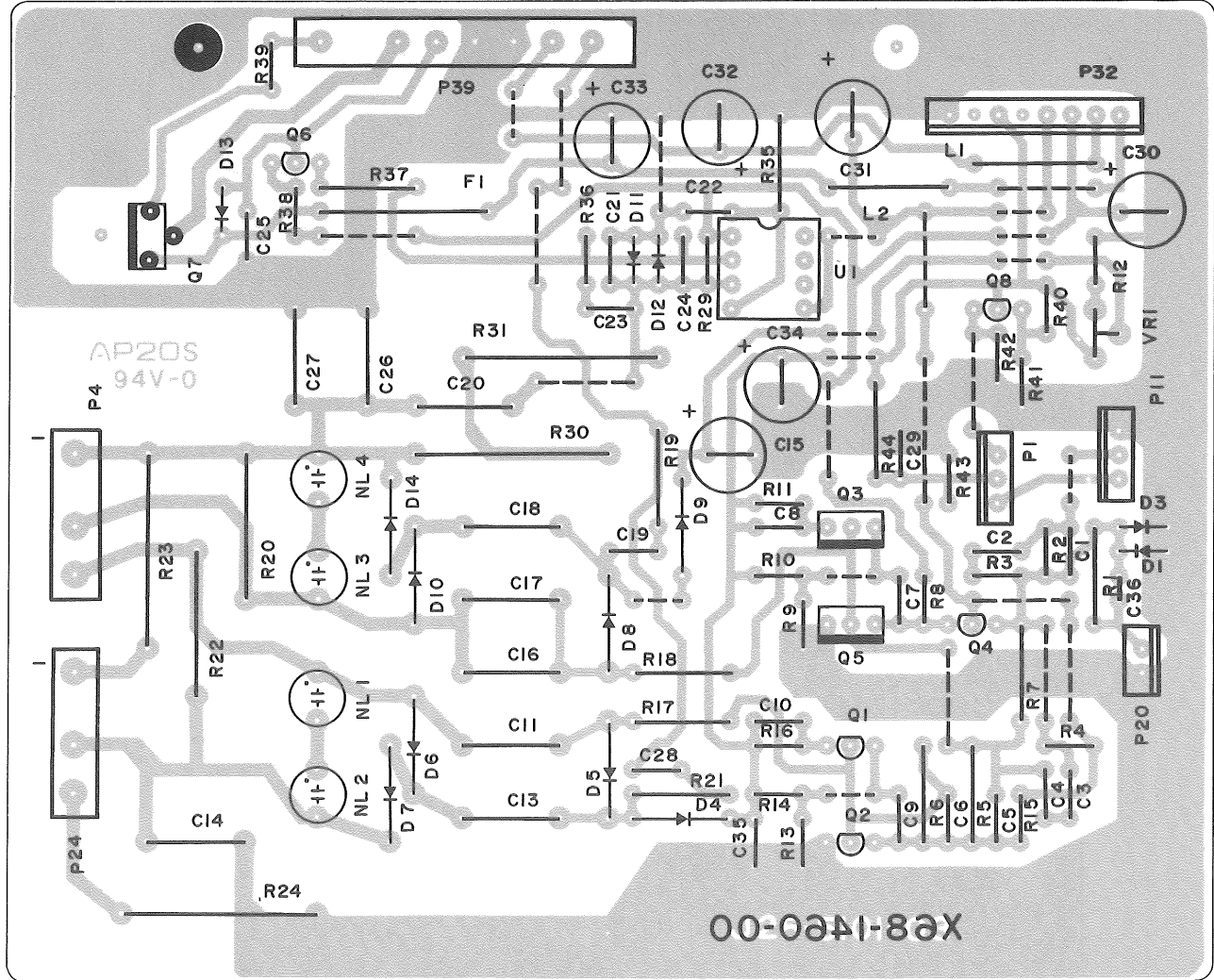


**POWER & FINAL AMP UNIT (X73-1660)**  
Foil side view

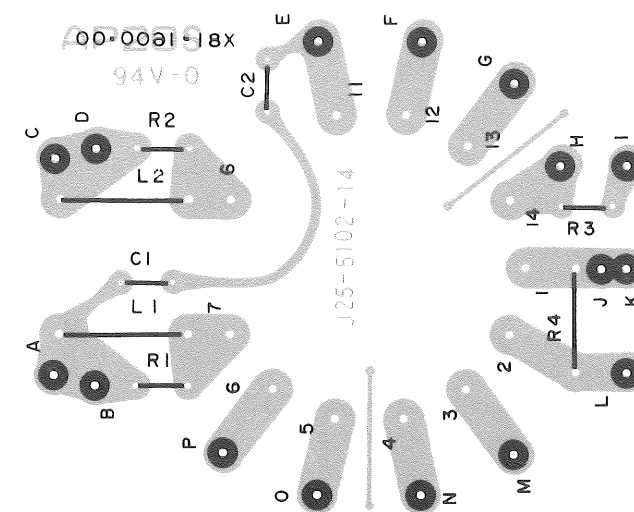


**P.C. BOARD**

**HIGH VOLTAGE UNIT (X68-1460)**  
Foil side view

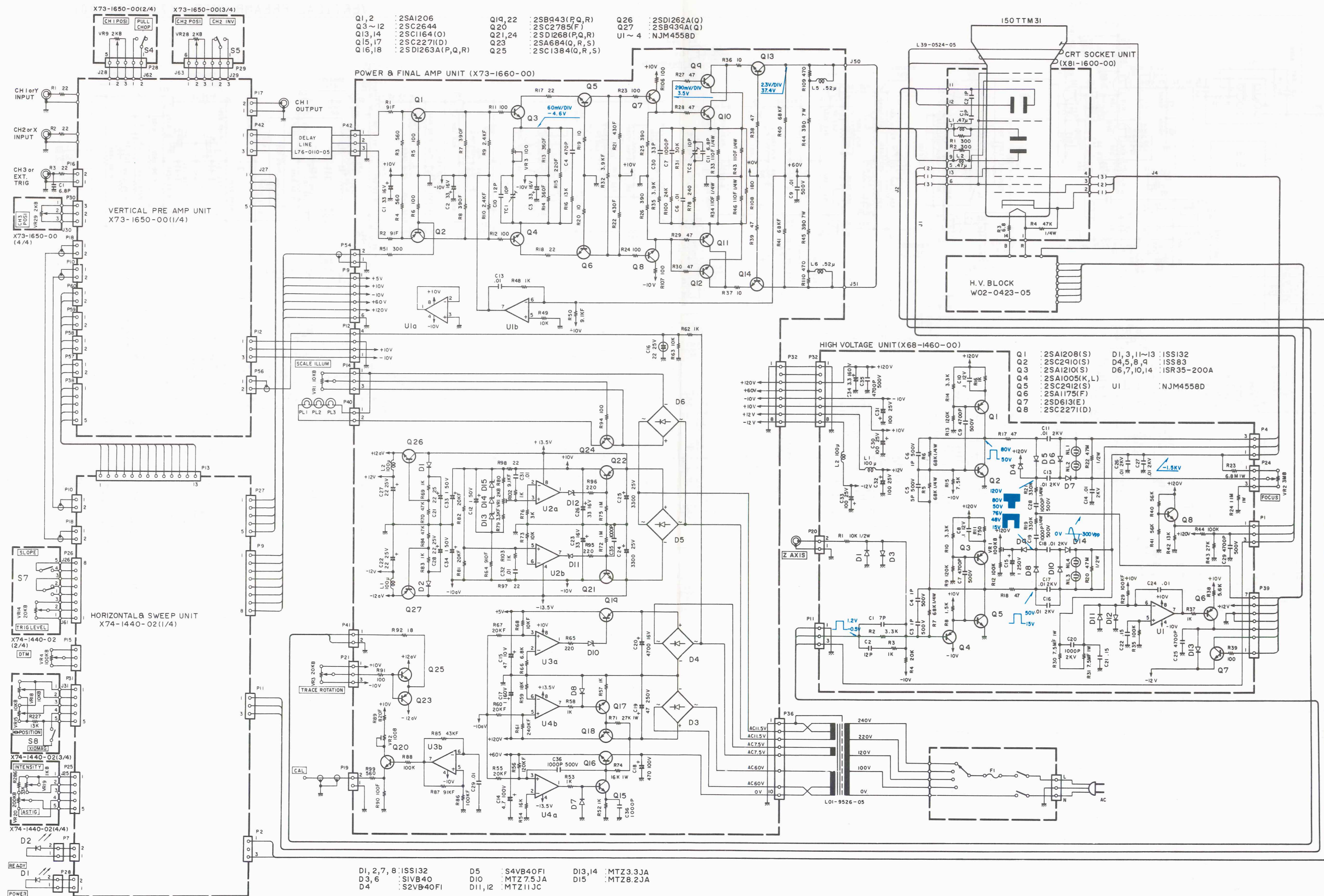


**CRT SOCKET UNIT (X81-1600)**  
Foil side view





# SCHEMATIC DIAGRAM





TH1 SDT1000  
TH2-4 SDT100

U1,3 LF411CN  
U2,4 CA3127E  
D1,4,15 1S1544A  
D10 MTZ7.5JC  
D7,12,13,18,19 MTZ5.1JB  
D2,3,5,6,8,9 1SS132  
11,14,16,17  
20,21

U1,3 LF411CN

U2,4 CA3127E

D1,4,15 1S1544A

D10 MTZ7.5JC

D7,12,13,18,19 MTZ5.1JB

D2,3,5,6,8,9 1SS132

11,14,16,17

20,21

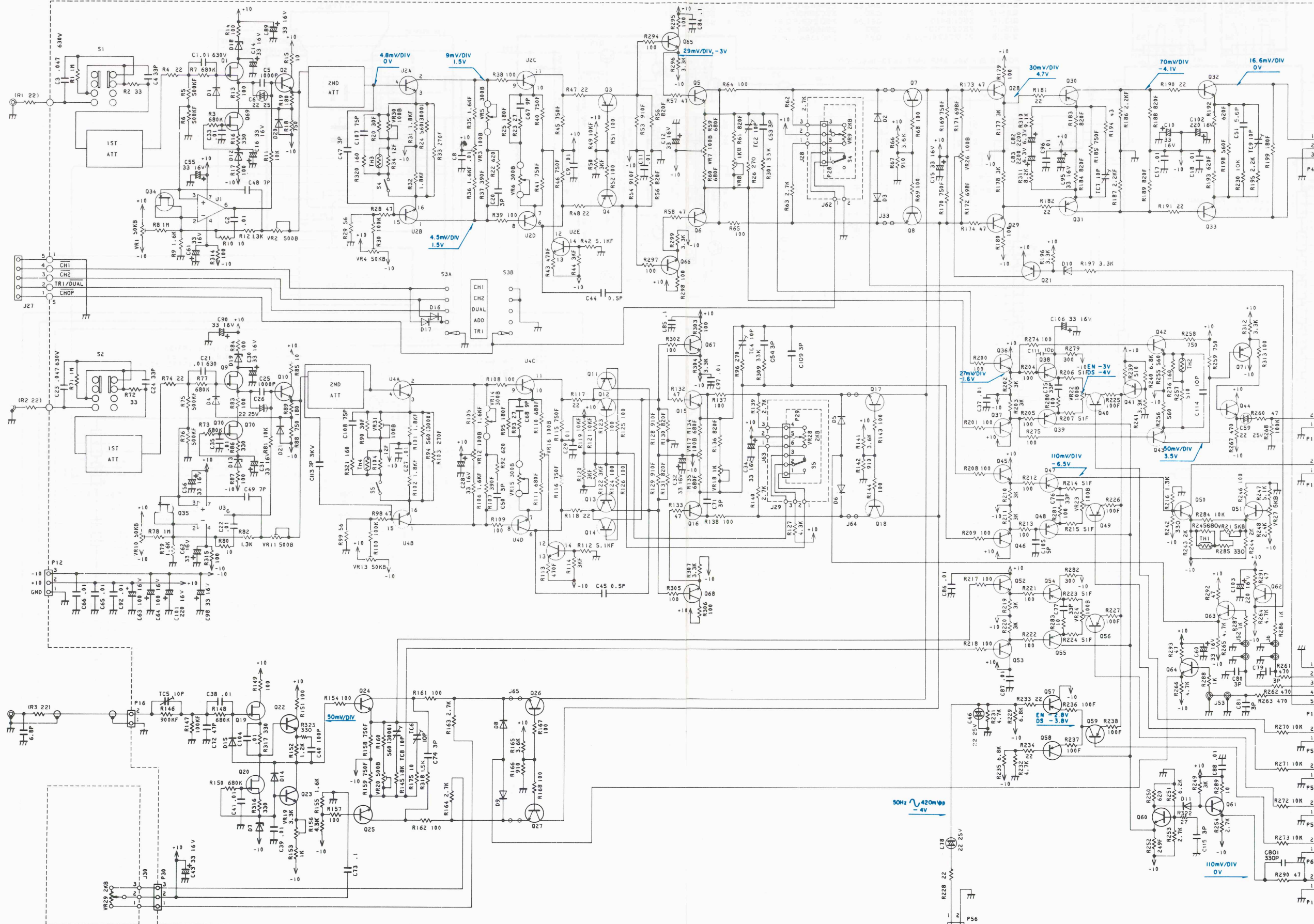
# SCHEMATIC DIAGRAM

Q1,9,19,20,69,70 2SK304(F)  
Q34,35 2SK184(T)  
Q57,58 2SA1175(F)  
Q30,31 2SA1206  
Q3,4,11-14,21 2SA1005(K)  
38-41,47-49  
54-56,59,71

Q32,33 2SC2644  
Q50,51,62-64 2SC2785(F)  
Q2,10,22,23,28 2SC3315(D)  
29,36,37,45,46  
52,53,65-68

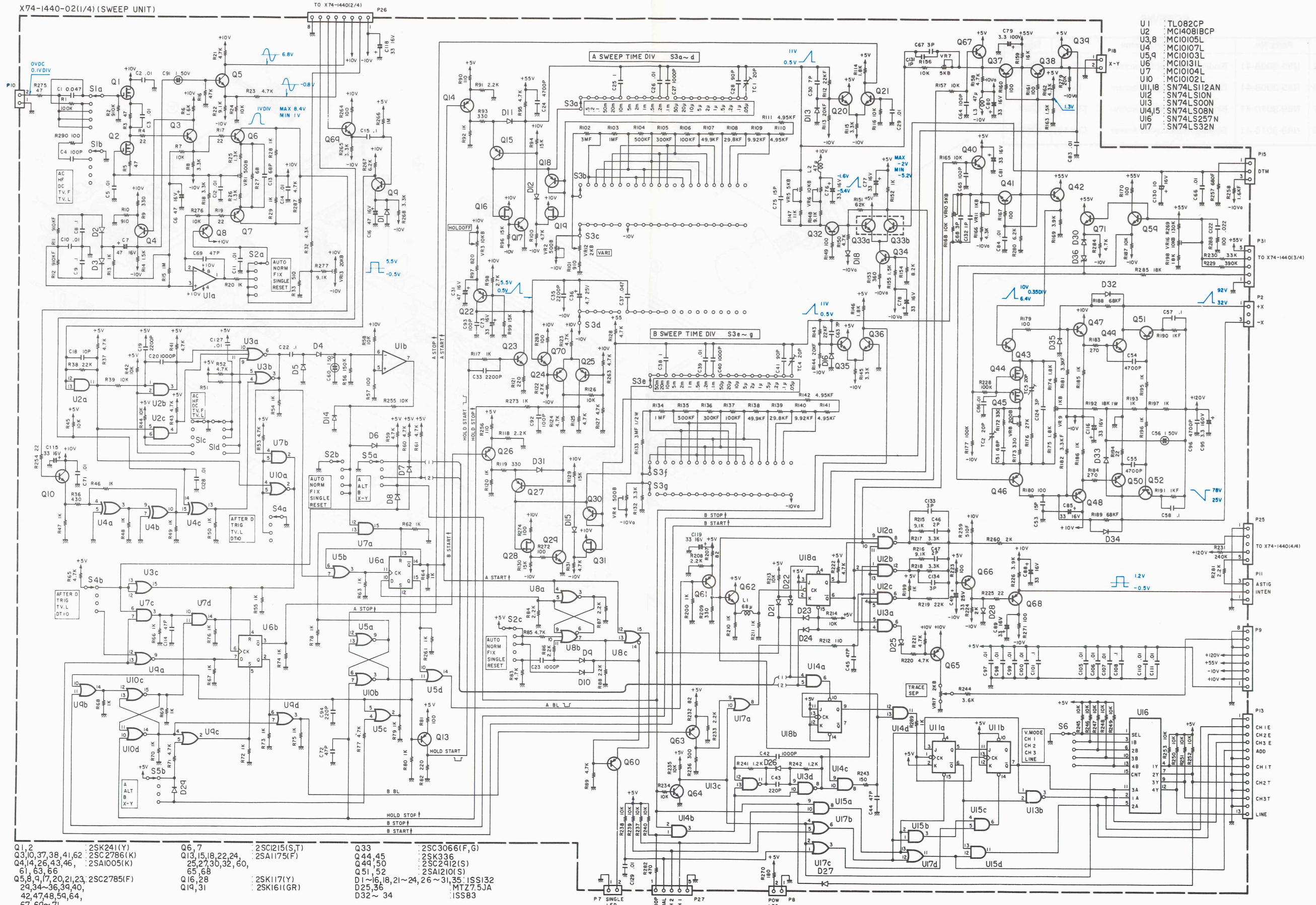
Q5-8,15-18,24-27 2SC3354(S,T)  
42,43,60,61  
Q44 2SC1973

## VERTICAL PREAMP UNIT (X73-1650-00)





# SCHEMATIC DIAGRAM



- U1 : TL082CP
- U2 : MC14081BCP
- U3,8 : MC10105L
- U4 : MC10107L
- U5,9 : MC10103L
- U6 : MC10104L
- U7 : MC10102L
- U11,18 : SN74LS12AN
- U12 : SN74LS10N
- U13 : SN74LS00N
- U14,15 : SN74LS08N
- U16 : SN74LS257N
- U17 : SN74LS32N

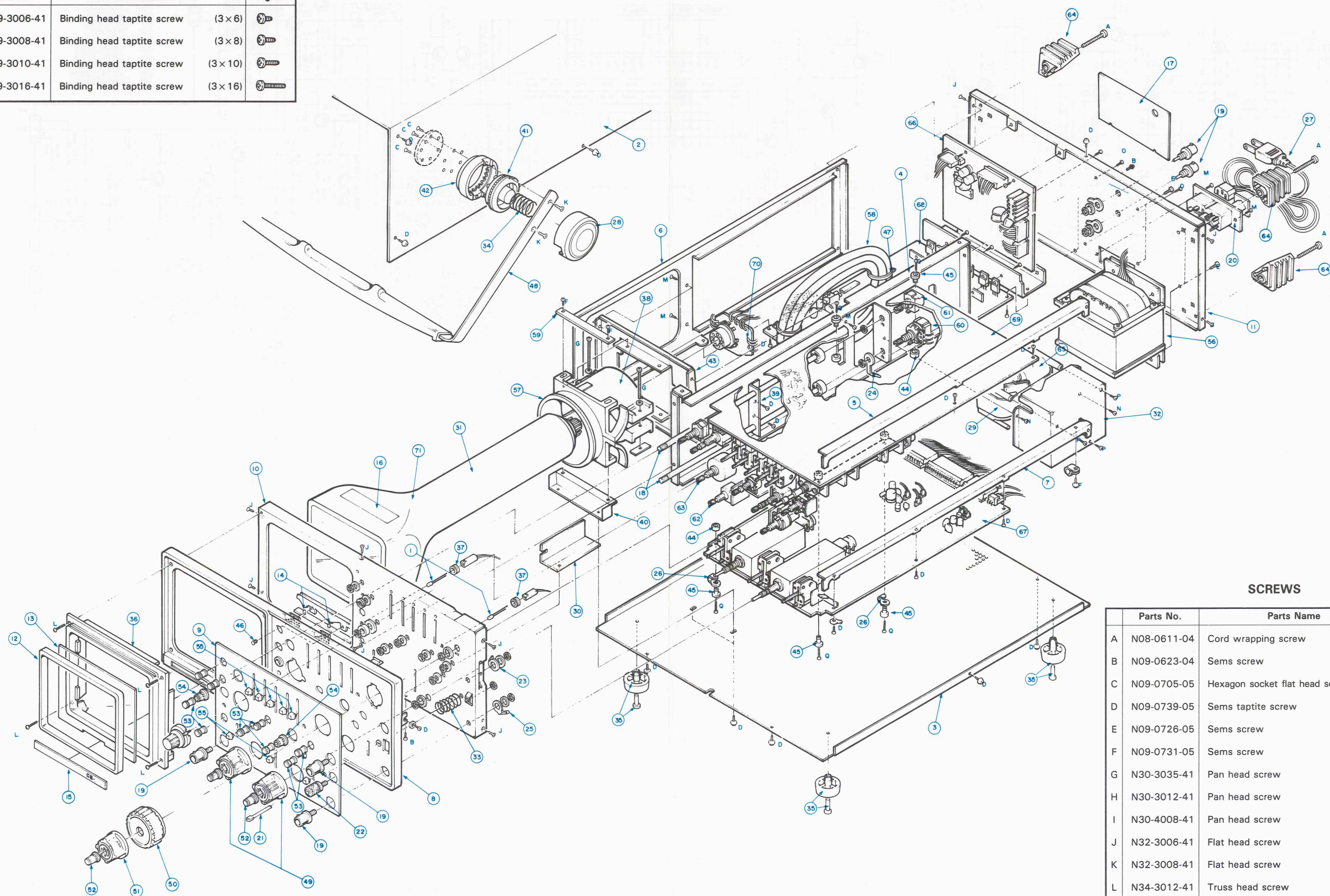
- |   |  |  |
|---|--|--|
| <p>Q1,2 : 2SK241(Y)</p> <p>Q3,10,37,38,41,62 : 2SC2786(K)</p> <p>Q4,14,26,43,46,61,63,66 : 2SA1005(K)</p> <p>Q5,8,9,17,20,21,23,29,34~36,39,40,42,47,48,59,64,67,69~71 : 2SC2785(F)</p> | <p>Q6,7 : 2SC1215(S,T)</p> <p>Q13,15,18,22,24,25,27,30,32,60,65,68 : 2SA1175(F)</p> <p>Q16,28 : 2SK117(Y)</p> <p>Q19,31 : 2SK161(GR)</p> | <p>Q33 : 2SC3066(F,G)</p> <p>Q44,45 : 2SK3336</p> <p>Q44,50 : 2SC2912(S)</p> <p>Q51,52 : 2SA1210(S)</p> <p>D1~16,18,21~24,26~31,35 : 1SS132</p> <p>D25,36 : MTZ7.5JA</p> <p>D32~34 : 1SS83</p> |
|---|--|--|



# DISASSEMBLY

## SCREWS

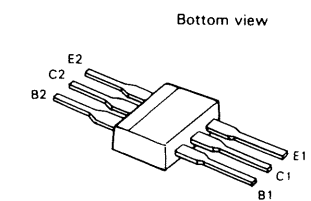
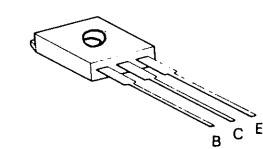
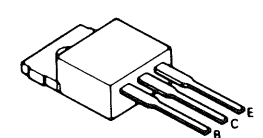
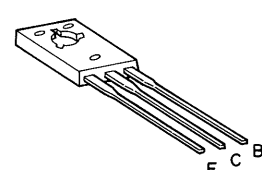
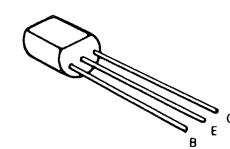
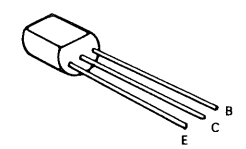
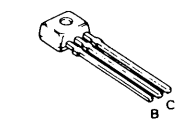
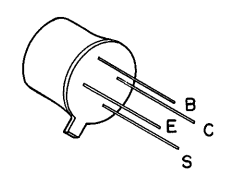
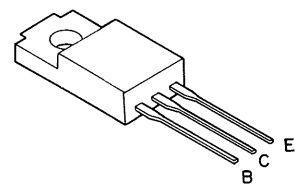
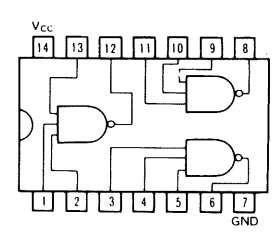
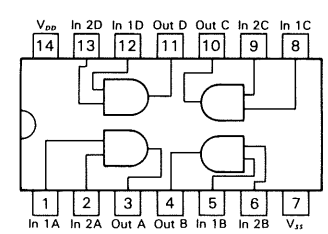
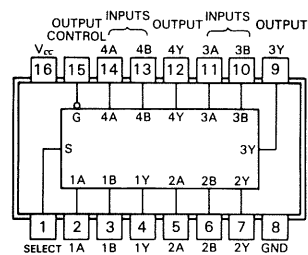
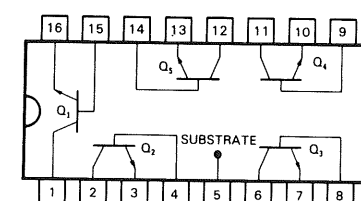
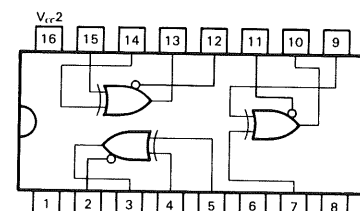
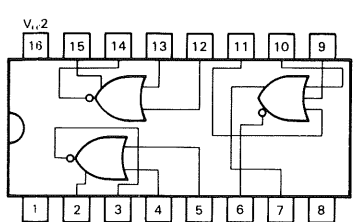
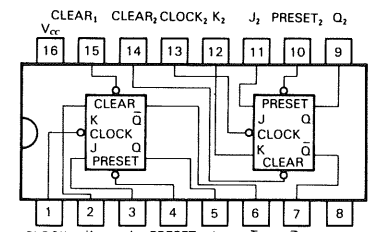
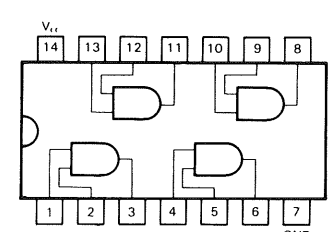
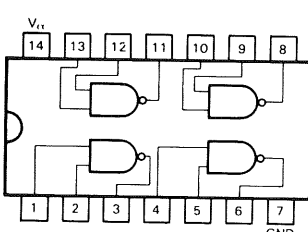
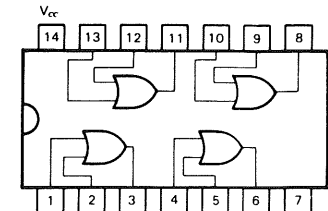
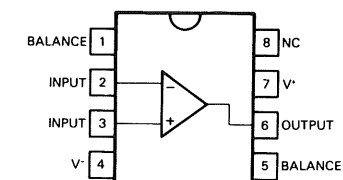
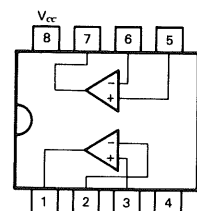
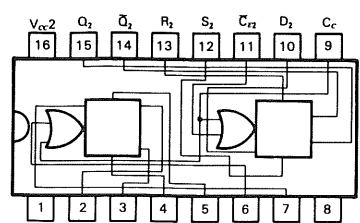
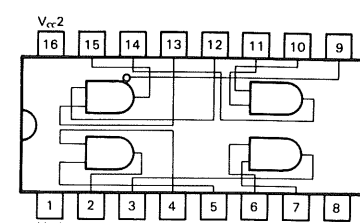
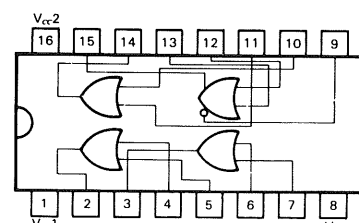
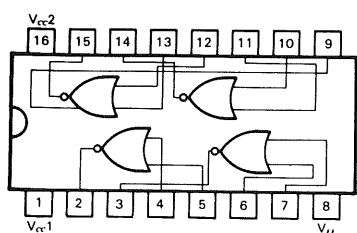
Parts No.	Parts Name	Figure
N	N89-3006-41 Binding head taptite screw (3 × 6)	
O	N89-3008-41 Binding head taptite screw (3 × 8)	
P	N89-3010-41 Binding head taptite screw (3 × 10)	
Q	N89-3016-41 Binding head taptite screw (3 × 16)	



## SCREWS

Parts No.	Parts Name	Figure
A	N08-0611-04 Cord wrapping screw	
B	N09-0623-04 Sems screw (M3 × 8)	
C	N09-0705-05 Hexagon socket flat head screw (M4 × 8)	
D	N09-0739-05 Sems taptite screw (3 × 8)	
E	N09-0726-05 Sems screw (M4 × 10)	
F	N09-0731-05 Sems screw (M3 × 12)	
G	N30-3035-41 Pan head screw (M3 × 35)	
H	N30-3012-41 Pan head screw (M3 × 12)	
I	N30-4008-41 Pan head screw (M4 × 8)	
J	N32-3006-41 Flat head screw (M3 × 6)	
K	N32-3008-41 Flat head screw (M3 × 8)	
L	N34-3012-41 Truss head screw (M3 × 12)	
M	N88-3008-41 Flat head taptite screw (3 × 8)	

# SEMICONDUCTORS

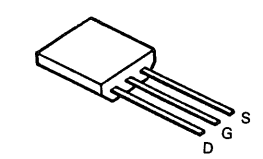
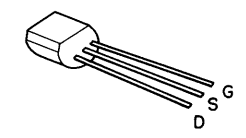
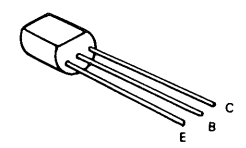
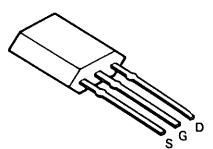
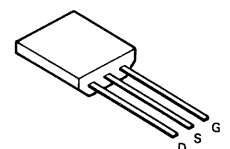
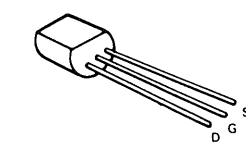
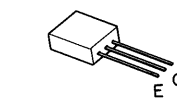


2SC2785 (F)  
2SC2786 (K)

2SA1005 (K,L)  
2SC1215 (S,T)  
2SC1384 (Q,R,S)  
2SC2271 (D)  
2SC1973  
2SA1208 (S)  
2SC2910 (S)

2SA1210 (S)  
2SC3596 (E)

2SD1262A (Q)



2SC3315 (D)

2SK161 (GR)

2SK304 (F)

2SK336

2SK336

2SK184 (Y)



---

A product of  
**KENWOOD CORPORATION**  
17-5, 2-chome, Shibuya, Shibuya-ku, Tokyo 150, Japan

---